



TSUGAMI
AMERICA

TMA8F

MILL/TURN MULTIFUNCTION MACHINE

- 65mm Thru Bore Multifunction Turning Center
- Five Axis Contour Capability
- 20,000 rpm B Axis Tool spindle with 60 Station Tool Carousel
- Sub Spindle A Axis with 6 Inch Chuck
- Fanuc 31i-B5 CNC Control

tsugamiamerica.com

TMA8F

MILL/TURN MULTIFUNCTION MACHINE

SPEED

- The standard 60 station tool magazine is located on the machine front so that operator can easily change and monitor tools.
- The high-speed cam driven tool change unit performs the tool-to-tool change at 0.8 sec.
- The unique 90° indexable tool spindle can reduce the number of tools and reduce tool change time by using a multi turning holder with four turning tools or can turn back and front faces with the same tool.
- 11kW powerful integral tool spindle can run max. 20,000 min-1, and performs milling as powerful as a machining center from low speed to high speed.

ACCURACY

- The orthogonal structure of the X-, Y-, Z-axes creates a high precision machining platform.
- The linear glass scales on the X1, Y1, and Z1 axis slide ensure high accuracy machining and repeatability.
- The thermally symmetrical structure also minimizes thermal displacement to ensure high-accuracy machining over a long term.

RIGIDITY

- The TMA8F is built on a heavy duty one piece cast iron base with thermally symmetrical construction. A more rigid platform allows higher speeds and feeds, and heavier depth of cut.
- For extra peace of mind, the machines, motors, and Fanuc controls are covered by an industry leading two-year parts and service warranty.

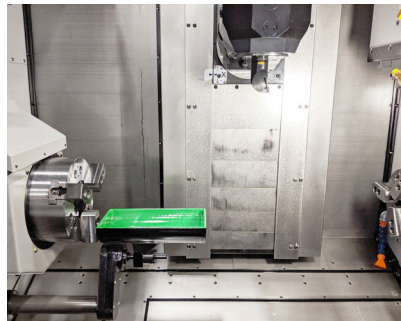

TMA8F Tool Zone



TMA8F Broken Tool Detection



TMA8F Tool Magazine

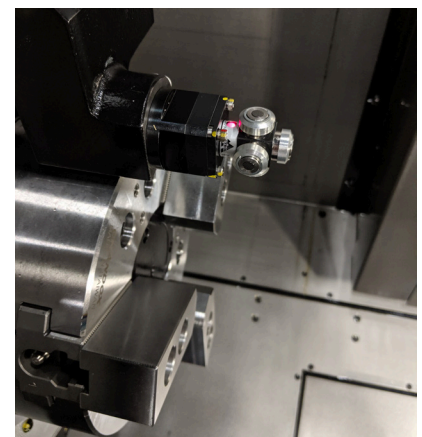

TMA8F Tool Presetter

ACCESSORIES

Your TMA8F can be accessorized with various tooling options. Some of these options include:



Royal QG Dead Length Collet Chuck System

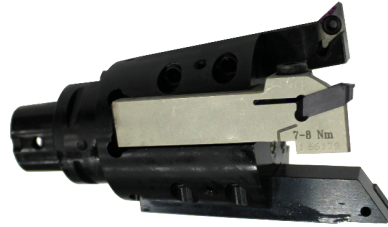

CAPTO C4 Tool Changer

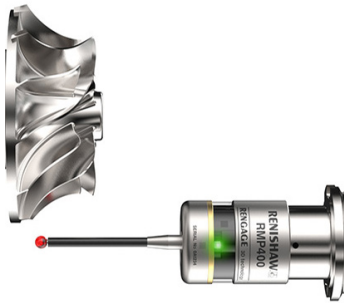

High-Accuracy Reinshaw Machine Probe



Laser Broken Tool Detection System

Our team can create anything needed to transform your tool zone to fit your part and process.

NEED SOMETHING CUSTOM?

From the machine Make Ready process, to integrating mechanical and robotic loading and unloading systems, to custom tool creation and spindle repair, IMG is dedicated to supporting all Tsgami users in North America!



Grinding Room



Make Ready Facility



Milling Room

TOOL SPINDLE

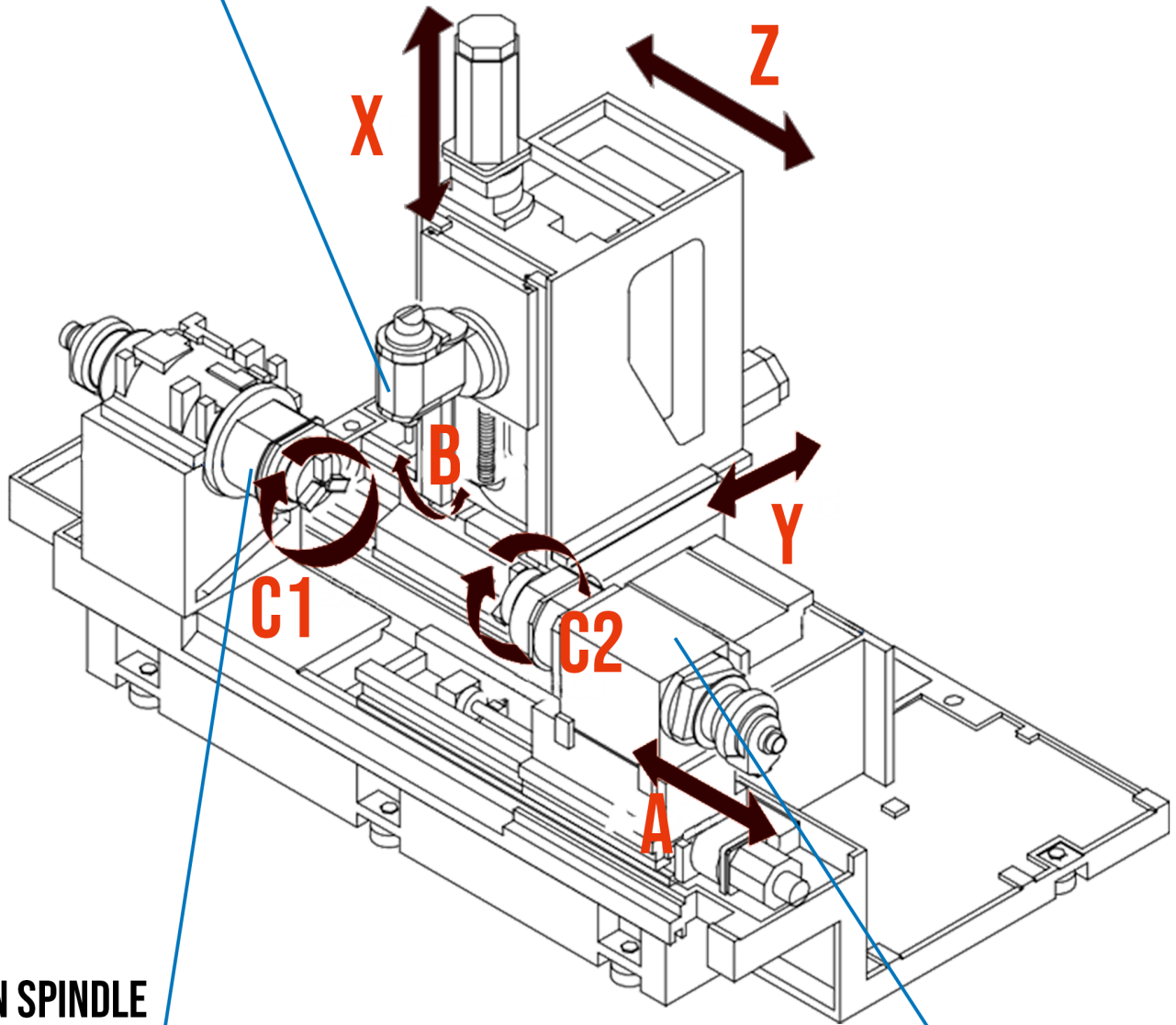

MAIN SPINDLE

BACK SPINDLE

MACHINE STANDARD SPECIFICATIONS

	ITEMS	TMA8F
CAPABILITY	Max. machining diameter	220 mm
	Max. barstock diameter	65 mm
	Max. machining length	580 mm
STROKE	X-axis stroke	430 mm
	Y-axis stroke	130 mm (+60/-70 mm)
	Z-axis stroke	580 mm (+ 30 mm)
	A-axis stroke	750 mm
MAIN SPINDLE	Max. spindle speed	5,000 min-1
	Spindle end face	JIS A2-6
	C1-axis least index angle	0.001°
	Chuck size	8"
	Motor output	20/15 Hp (15/11 kW)
BACK SPINDLE	Max. spindle speed	5,000 min-1
	Spindle end face	ø140 mm flat nose
	C2-axis least index angle	0.001°
	Chuck size	6 inch
	Motor output	10/7.5 Hp (7.5/5.5 kW)
TOOL SPINDLE	Max tool diameter	80mm
	Type of tool spindle	Single tool spindle with ATC
	Motor output	15/7.5 Hp (11/5.5 kW)
	B-axis index angle	-15° to 195°
	B-axis least index angle	0.001° (Continuous control)
	Tool spindle indexing angle/position	90°/4 positions
	Max. tool spindle speed	20,000 min-1
	Max tool length	220mm
ATC	Tool shank configuration	CAPTO C4
	Tool storage capacity	60 stations
RAPID REVERSE RATE	X-axis rapid traverse rate	30 m/min
	Y-axis rapid traverse rate	24 m/min
	Z-axis rapid traverse rate	40 m/min
	A-axis rapid traverse rate	30 m/min
	C-axis rapid traverse rate	300 min-1
	B-axis rapid traverse rate	150 min-1
MACHINE SIZE	Machine height	2,140 mm (84.25")
	Floor requirements	3,700 mm x 2,126 mm (145.67" x 83.7")
	Machine weight	8,500 kg (18,739 lbs.)

NC SPECIFICATIONS

ITEMS

TMA8F

NC Unit	FANUC 31i-B5
Display Unit	10.4" color LCD
Controllable axes	7 axes (Simultaneously controllable axes: 5 axes)
Interpolation function	Linear interpolation, circular interpolation, polar coordinate interpolation, cylindrical interpolation, helical interpolation
Part program storage size	1 Mbyte with Standard 4 GB Data Server
Number of registrable programs	1,000
Edit function	Background editing, programmable data input
Operation control	Run time & parts number display
Tape code	Automatic recognition of EIA/ISO
Command method	Standard: G code system A
Least input increment	0.001 mm 0.0001°
Max. programmable value	±99999.999 mm / (±8 digits)
Program command	Workpiece coordinate system (G52 to G59), machine coordinate system, 3-dimensional coordinate conversion
Canned cycle	Canned cycle, multiple repetitive cycle, canned cycle for drilling
Spindle control	Direct command of S 5-digit, 0 - 120% override per 10%, constant surface speed control, main/back-spindle synchronization, Cs contour control, rigid tapping
Tool offset	Tool geometry offset and tool wear offset, cutter and tool nose radius compensation
Number of tool offsets	200
Tool function	T code 5-digit (First 2 digits: Tool number, Last 3 digits: Offset number)

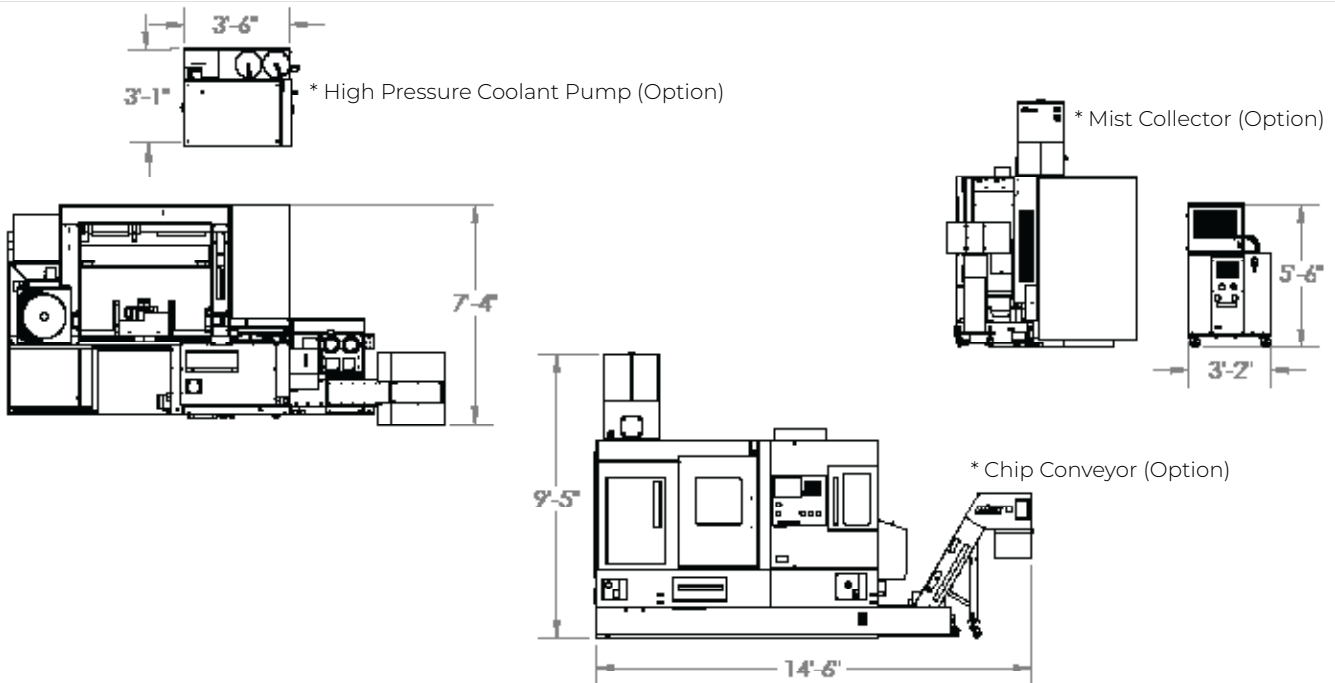

Since 1978, Tsugami America (formerly known as Tsugami/Rem Sales) has been the exclusive source for Precision Tsugami CNC machine tools in North America. Headquartered in Windsor, CT, Tsugami America provides machine tools and engineering expertise through an extensive network of authorized distributors and technical centers. Technical support and customer service are available throughout North America. Our distributors' trained service personnel provide technical support throughout the long life-cycle of our Tsugami machine tools, and work hand-in-hand with Tsugami America's engineers to deliver common-sense solutions to everyday problems.

Our application engineers help customers tackle and solve the toughest high-precision manufacturing challenges, on-time and on-budget. We have a 35-year history and reputation of serving the needs of small parts manufacturers in North America with the highest level of expertise and customer care. Our industry-respected, knowledgeable staff is comprised of both long-time employees and fresh faces all who share a commitment to provide you, our customers, with the competitive advantage to "do more with less" every day.

DISTRIBUTION NETWORK

The Robert E. Morris Company

Serving: CT, MA, RI, NH, VT, ME, NY, NJ
www.robertemorris.com

Morris Midwest Wisconsin & Illinois

Serving: WI, IL, MI Upper Peninsula
www.morrismidwest.com

Methods & Equipment Associates

Serving: MI
www.methods-equipment.com

Ellison Technologies

Serving: CA, WA, OR, NV
www.ellisontechnologies.com

MAQUIPRIME

Serving: Mexico
www.maquiprime.com.mx

Morris South

Serving: NC, SC, GA, VA, AL, MS, TN, AR, FL
www.morrissouth.com

Morris Great Lakes

Serving: NY, PA, WV
www.morrisgreatlakes.com

Technical Equipment Sales Co

Serving: OH, IN, KY
www.techequip.com

Hartwig, Inc.

Serving: MO, IL, IA, KS, CO, OK, TX, LA, MT, UT, NM, ID, WY
www.hartwiginc.com

Morris Midwest Minnesota

Serving: MN, ND, SD
www.morrismidwest.com

Precision 360

Serving: FL, PA, NJ, DE, MD
www.precision360.com

Arizona CNC

Serving: AZ, NV
www.arizonacnc.com

EMEC Machine Tools Inc.

Serving: Eastern Canada
www.emecmt.com

Thomas Skinner

Serving: Western Canada
www.thomasskinner.com

TSUGAMI AMERICA LOCATIONS

WINDSOR, CT

651 Day Hill Road
Windsor, CT 06095

FORT WAYNE, IN

4501 Earhart Drive, Suite B
Fort Wayne, IN 46809

BROOKLYN PARK, MN

9495 Winnetka Avenue N, Suite 100
Brooklyn Park, MN 55445

FULLERTON, CA

1521 E Orangethorpe Ave, Suite E
Fullerton, CA 92831

860-687-3400 | www.tsugamiamerica.com | info@tsugamiamerica.com

TSUGAMI AMERICA IS ISO 9001:2015 CERTIFIED QMS