

**TSUGAMI**  
AMERICA

# SS327-III-5AX

## CNC PRECISION AUTOMATIC LATHE

- 32mm Capacity Chucker Convertible Swissturn
- B Axis Tool Spindle for Angular Live Work or 5-Axis Milling
- Main Side Gang with 7 Turning Tools, 8 Driven Tools (2 Modular), and 4 Id Tool Positions
- Sub Side Y Axis with 8 Driven Tool Positions (4 Standard), up to 36 Total Tools Available
- Oscillation Cutting Capable
- Direct Drive Guide Bushing
- FANUC 31i-B5 CNC Control

[tsugamiamerica.com](http://tsugamiamerica.com)

# SS327-III-5AX

## B-AXIS SLIDING HEADSTOCK SWISS TYPE LATHE

### SPEED

- The SS327-III-5AX is chucker convertible with a modular B-axis allowing for the cutting of complex parts, complete in a single setup, while applying the capability for through hole thread whirling or high speed spindles for small surfacing end mills.
- The B-axis contains live tools (four front, two rear) which can machine in coordination with the C-axis, delivering the ability to cut precise angles and sculpted contours.
- The overlap capabilities with the Y2 axis and its 8 modular driven tool positions, mean more work is done to reduce your cycle time.

### ACCURACY

- Tsugami has a long-term reputation for machine accuracy. It's all starts with their world-class engineering, incorporating symmetrically designed castings and an "A-frame" design of the gang slide. Utilizing the highest quality, motors, ball screws, rails and bearings assure precise motion control, and unique spindle cooling all work in concert and contribute to repeatable accuracy over the long life of the machine tool.

### RIGIDITY

- Tsugami has the most rigid gang tool post in the industry due to opposing rail slides.
- Built on a heavy duty one piece cast iron base with thermally symmetrical construction, this machine features 0.1 micron axis resolution. A more rigid platform allows higher speeds and feeds.
- For extra peace of mind, the machines, motors, and FANUC controls are covered by an industry leading two-year parts and service warranty.

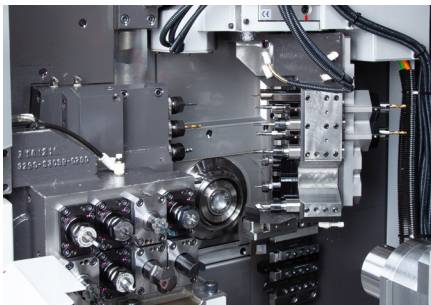

SS327-III-5AX Tool Zone

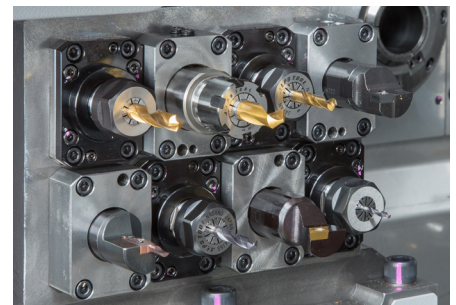

SS327-III-5AX Backworking Block

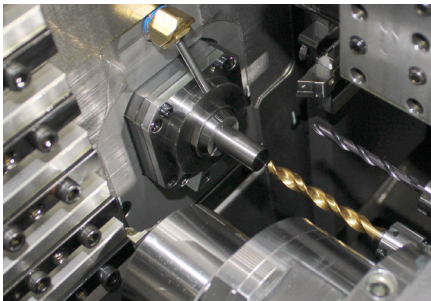

Deep Hole Drilling

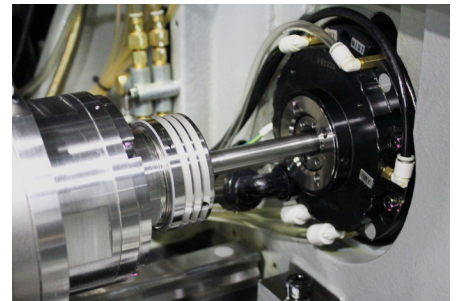

Servo Driven Guide Bushing

# WORK ZONE & MODULAR TOOLING

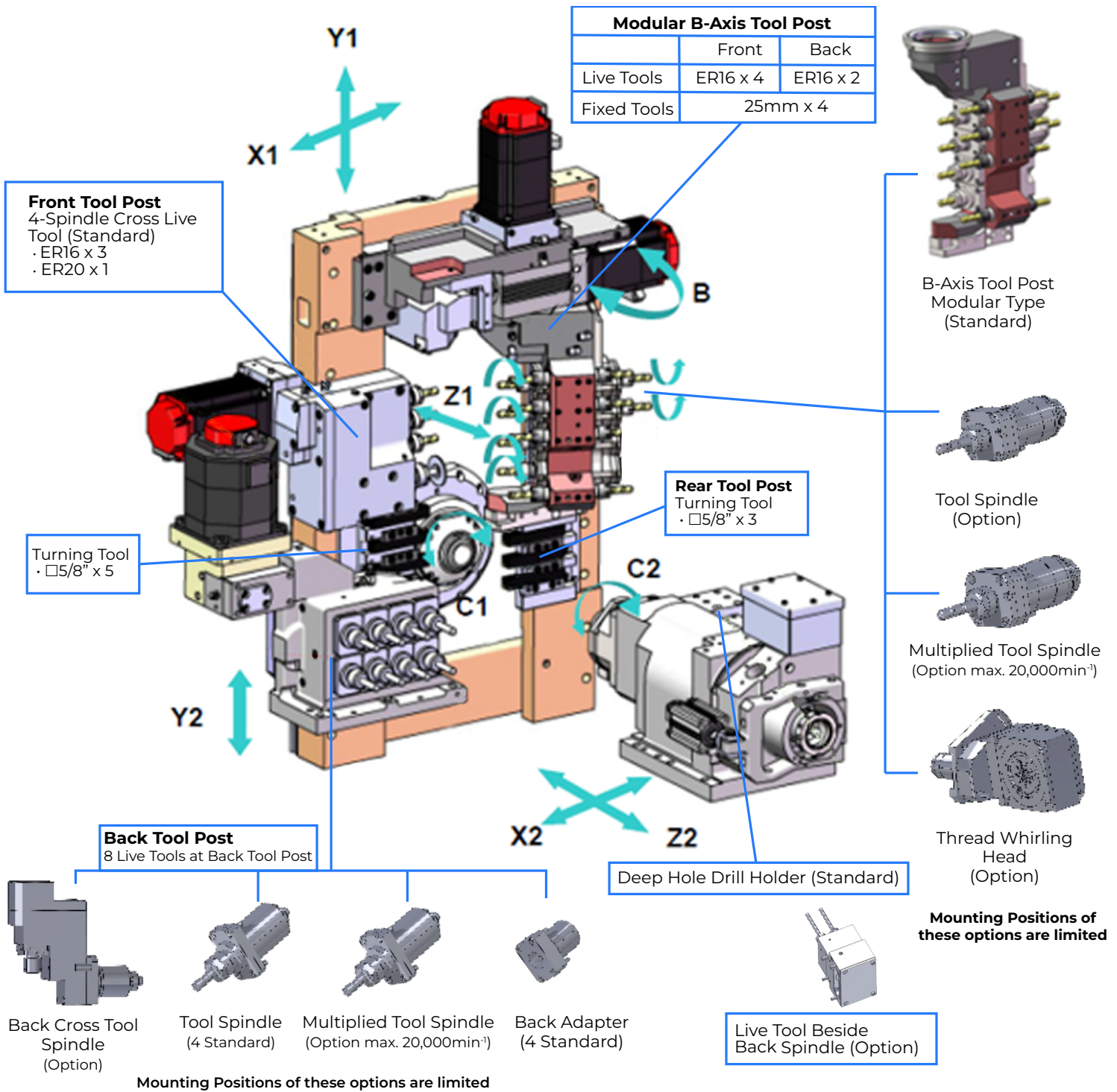

# ACCESSORIES

Your SS327-III-5AX can be accessorized with various tooling options. Some of these options include:



Back Tool Spindle



Static Adapter



Quick Change Tooling

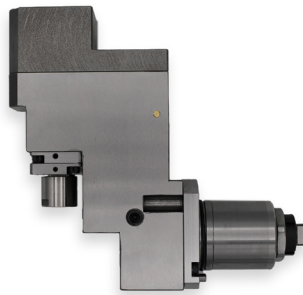

Back Cross Tool Spindle

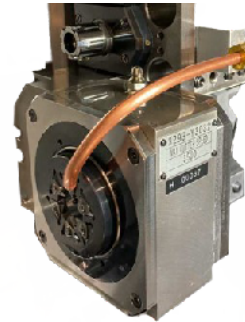

B-Axis Thread Whirling Head

Our team can create anything needed to transform your tool zone to fit your part and process.

## NEED SOMETHING CUSTOM?

From the machine Make Ready process, to integrating mechanical and robotic loading and unloading systems, to custom tool creation and spindle repair, IMG is dedicated to supporting all Tsgami users in North America!



Grinding Room



Make Ready Facility



Milling Room

# OSCILLATION CUTTING

Oscillation Cutting is a technological breakthrough that oscillates a servo axis to help break chips in tough to cut materials, reduces heat in the cut, while not diminishing tool life.

- Productivity is increased by significantly reducing operator interruption to remove hanging or bird nesting chips.
- Easy to program by special G code
- Oscillation parameters can be changed easily within the program for machining multiple features with multiple tools.
- Can be used for many machining operations including OD turning, drilling, boring, grooving, cutoff, circular interpolation, and most FANUC canned cycles.

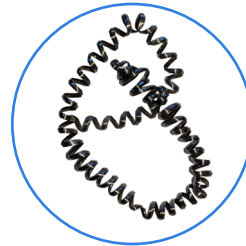

**WITHOUT  
OSCILLATION**

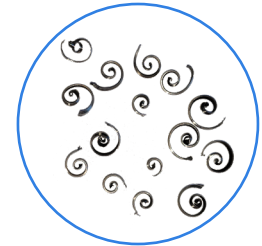

**WITH  
OSCILLATION**

*AVAILABLE ON ALL PATHS*

## ABILE SOFTWARE

- Developed by Tsugami, Abile is capable of programming moderately complex machined parts. Abile incorporates all basic machines featured and several material types with predetermined feed rates.
- Abile allows first time users to quickly become proficient with Swiss processing despite having limited knowledge. Abile comes free with your machine purchase and requires no license fees, maintenance agreements, or seat limitations.
- Abile allows you to generate a 2 or 3-path part program, complete, with specific and editable codes in standard FANUC G Code format. Abile automatically generates machine process and provides component run times.

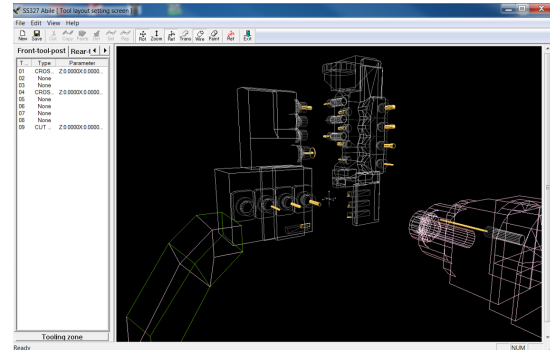

Program Generator

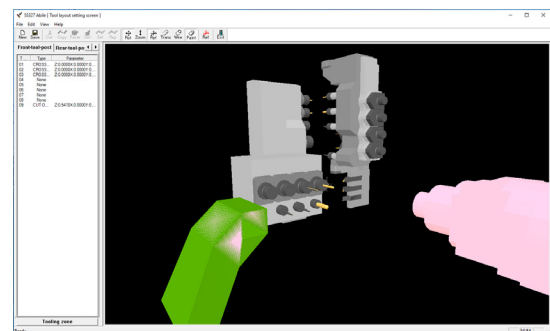

Tool Setting

# MACHINE STANDARD SPECIFICATIONS

## ITEMS

## SS327-III-5AX

### MACHINING RANGE

### MACHINING CAPABILITY

### MOTORS

### OTHER

Working Barstock Diameter	ø32 mm (1.26 in.)
Max. Machining Length	330 mm (12.99 in.) (Direct-Drive Guide Bushing) 70 mm (2.76 in.) (Chucker Mode)
Max. Main Spindle Drilling Diameter	ø12 mm (.47 in.)
Max. Main Spindle Tapping Diameter	M10
Max. Back Spindle Chucking Diameter	ø32 mm (1.26 in.)
Max. Back Spindle Drilling Diameter	ø10 mm (.393 in.)
Max. Back Spindle Tapping Diameter	M8
Max. Tool Spindle Slotting Cutter Diameter	ø45 mm (1.77 in.)
Max. Back Drilling Diameter	ø8 mm (.31 in.)
Max. Back Live Tapping Diameter	M6
Main Spindle Speed	200 to 8,000 min <sup>-1</sup>
Back Spindle Speed	200 to 8,000 min <sup>-1</sup>
Tool Spindle Speed	200 to 6,000 min <sup>-1</sup>
Total Tool Number (Standard Spec.)	38
Tool Size	.625 in. x 3.94 in. (square) / 25 mm (round)
Rapid Traverse Rate	35 m/min (105 ft/min) [(X1, Y1, Z2: 24 m/min (78.74 ft/min)]
B-Axis Tool Spindle Speed	7,000 RPM
Spindle Index	C1 Axis and C2 Axis
Main Spindle	5/7.5 Hp (3.7/5.5 kW)
Back Spindle	5/7.5 Hp (3.7/5.5 kW)
Cross Drill of Front Tool Post	1.5 Hp (1.0 kW)
B-Axis Tool Spindle	1.5 Hp (1.0 kW)
Rotary Tool of Back Tool Post	1.9 Hp (1.4 kW)
Rotary Guide Bushing	2 Hp (1.5 kW)
Z1, Y1, X2, Z2	1 Hp (0.75 kW)
X1, Y2	0.7 Hp (0.5 kW)
Coolant Pump	0.5 Hp (.4 kW)
Lubricating Pump	4 Hp 3.7(3kW)
Compressed air requirement	.4 MPa or more
Air discharge rate	100 NL/min
Power Source Requirements	16.8 KVA
Coolant Tank Capacity	260 L
Width x depth x height	2630 x 1280 x 2010 mm 103.5" x 50.4" x 79"
Weight	4,000 kg (8,818 lbs.)

# NC SPECIFICATIONS

## ITEMS

## SS327-III-5AX

NC Unit	FANUC 31i-B5
Axis Name	X1, Z1, Y1, X2, Y2, Z2, C1, C2
Least Input Increment	0.001 mm (X1/X2 axis in diameter)
Least Command Increment	X1/X2 axis: 0.0005 mm, other: 0.001 mm
Maximum Programmable Value	± 8 digits
Interpolation Method	Linear/Circular/Polar/Helical/Cylindrical
Rapid Traverse Function	35 m/min (115 ft/min) (X1/Y1/Y2 24 m/min (78.74 ft/min))
Feedrate Function	1 to 6,000 mm/min
Feedrate Override	0 to 150%, 10% step
Dwell	G04 0 to 99999.999
ABS/INC Command	X, Z, Y, C: Absolute U, W, V, H: Incremental
Tool Offset Value	± 6 digits
Tool Offset Pairs	99
LCD/MDI	10.4" color LCD
Display Language	English
Data Server	4 GB
Registrable Programs	1000
Auxiliary Function	Main: M Code 5 digits
Spindle Function	S Code 5 digits
Tool Function	T Code 4 digits

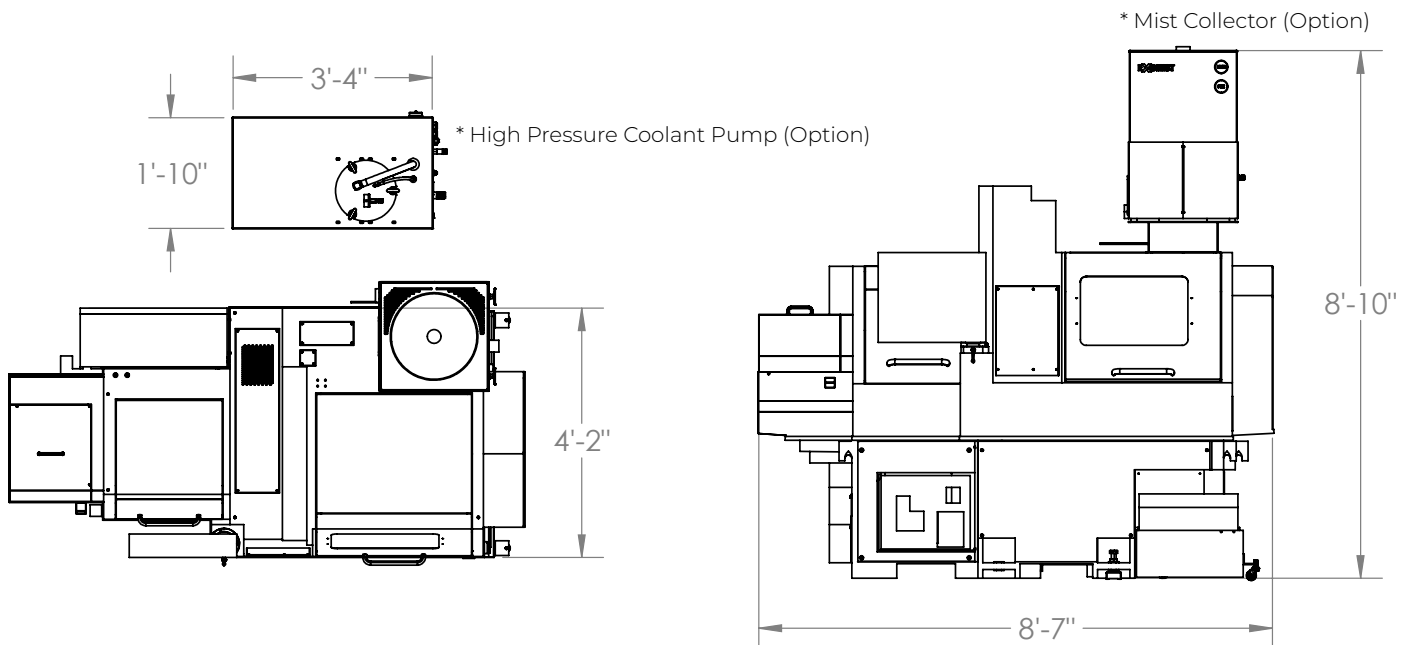

Since 1978, Tsugami America (formerly known as Tsugami/Rem Sales) has been the exclusive source for Precision Tsugami CNC machine tools in North America. Headquartered in Windsor, CT, Tsugami America provides machine tools and engineering expertise through an extensive network of authorized distributors and technical centers. Technical support and customer service are available throughout North America. Our distributors' trained service personnel provide technical support throughout the long life-cycle of our Tsugami machine tools, and work hand-in-hand with Tsugami America's engineers to deliver common-sense solutions to everyday problems.

Our application engineers help customers tackle and solve the toughest high-precision manufacturing challenges, on-time and on-budget. We have a 40-year history and reputation of serving the needs of small parts manufacturers in North America with the highest level of expertise and customer care. Our industry-respected, knowledgeable staff is comprised of both long-time employees and fresh faces all who share a commitment to provide you, our customers, with the competitive advantage to "do more with less" every day.

## DISTRIBUTION NETWORK

### **The Robert E. Morris Company**

Serving: CT, MA, RI, NH, VT, ME, NY, NJ  
[www.robertemorris.com](http://www.robertemorris.com)

### **Morris Midwest Wisconsin & Illinois**

Serving: WI, IL, MI Upper Peninsula  
[www.morrismidwest.com](http://www.morrismidwest.com)

### **Methods & Equipment Associates**

Serving: MI  
[www.methods-equipment.com](http://www.methods-equipment.com)

### **Ellison Technologies**

Serving: CA, WA, OR, NV  
[www.ellisontechnologies.com](http://www.ellisontechnologies.com)

### **Protecnic de México, S.A de C.V.**

Serving: Mexico  
[www.protecnic.com.mx](http://www.protecnic.com.mx)

### **Morris South**

Serving: NC, SC, GA, VA, AL, MS, TN, AR, FL  
[www.morrissouth.com](http://www.morrissouth.com)

### **Morris Great Lakes**

Serving: NY, PA, WV  
[www.morrisgreatlakes.com](http://www.morrisgreatlakes.com)

### **Technical Equipment Sales Co**

Serving: OH, IN, KY  
[www.techequip.com](http://www.techequip.com)

### **Hartwig, Inc.**

Serving: MO, IL, IA, KS, CO, OK, TX, LA, MT, UT, NM, ID, WY  
[www.hartwiginc.com](http://www.hartwiginc.com)

### **Morris Midwest Minnesota**

Serving: MN, ND, SD  
[www.morrismidwest.com](http://www.morrismidwest.com)

### **Precision 360**

Serving: FL, PA, NJ, DE, MD  
[www.precision360.com](http://www.precision360.com)

### **Arizona CNC**

Serving: AZ, NV  
[www.arizonacnc.com](http://www.arizonacnc.com)

### **EMEC Machine Tools Inc.**

Serving: Eastern Canada  
[www.emecmt.com](http://www.emecmt.com)

### **Thomas Skinner**

Serving: Western Canada  
[www.thomasskinner.com](http://www.thomasskinner.com)

## TSUGAMI AMERICA LOCATIONS

### **WINDSOR, CT**

651 Day Hill Road  
Windsor, CT 06095

### **FORT WAYNE, IN**

4501 Earhart Drive, Suite B  
Fort Wayne, IN 46809

### **BROOKLYN PARK, MN**

9495 Winnetka Avenue N, Suite 100  
Brooklyn Park, MN 55445

### **FULLERTON, CA**

1521 E Orangethorpe Ave, Suite E  
Fullerton, CA 92831

860-687-3400 | [www.tsugamiamerica.com](http://www.tsugamiamerica.com) | [info@tsugamiamerica.com](mailto:info@tsugamiamerica.com)

**TSUGAMI AMERICA IS ISO 9001:2015 CERTIFIED QMS**