



TA | FA | SA

Performance Line

Born Reliable. Born Precise.

 **SORALUCE**

As part of our premium solutions, the **Performance Line** offers the highest reliability and precision along with an outstanding flexibility. Three state-of-the-art families to boost **quality**, **competitiveness**, ease of use, ergonomics and safety.



Reliable
Precise
Flexible

TOP BENEFITS	RELIABILITY	PRECISION	PRODUCTIVITY	FLEXIBILITY
Design	■	■	■	■
Full cast iron structure	■	■	■	
Multiple configurations			■	■
Linear guiding & Damping Pads	■	■	■	
DAS+	■	■	■	
Driving system	■	■	■	

FA: Floor type milling machine
TA: Bed type milling machine
SA: Fixed table travelling column milling machine



Performance Line

Born Reliable.

Proven quality components

- High performance 7000 rpm heads.
- Direct drive inline motor.
- Robust software.

Born Precise.

Best geometric stability

- Water-based cooling.
- Real-time thermal compensation.

Born Flexible.

Solutions adapted to your needs

- Easy integration of milling & turning tables.
- New choice of milling heads with higher spindle speed.



Modularity made by you

One structure,
three architectures,
endless solutions.

3 models based on the same structure-concept,
resulting on multiple solutions adapted to your
machining requirements.

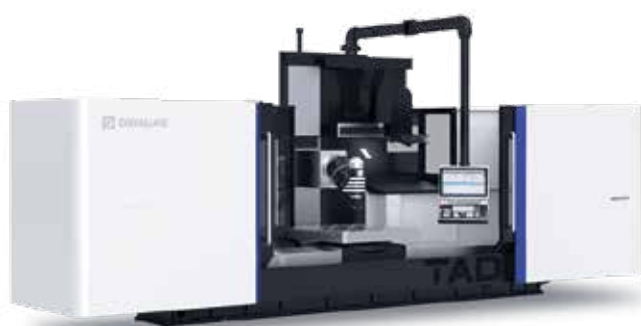

TA

Bed type
milling machine



FA

Floor type
milling machine



SA

Fixed table travelling
column milling machine

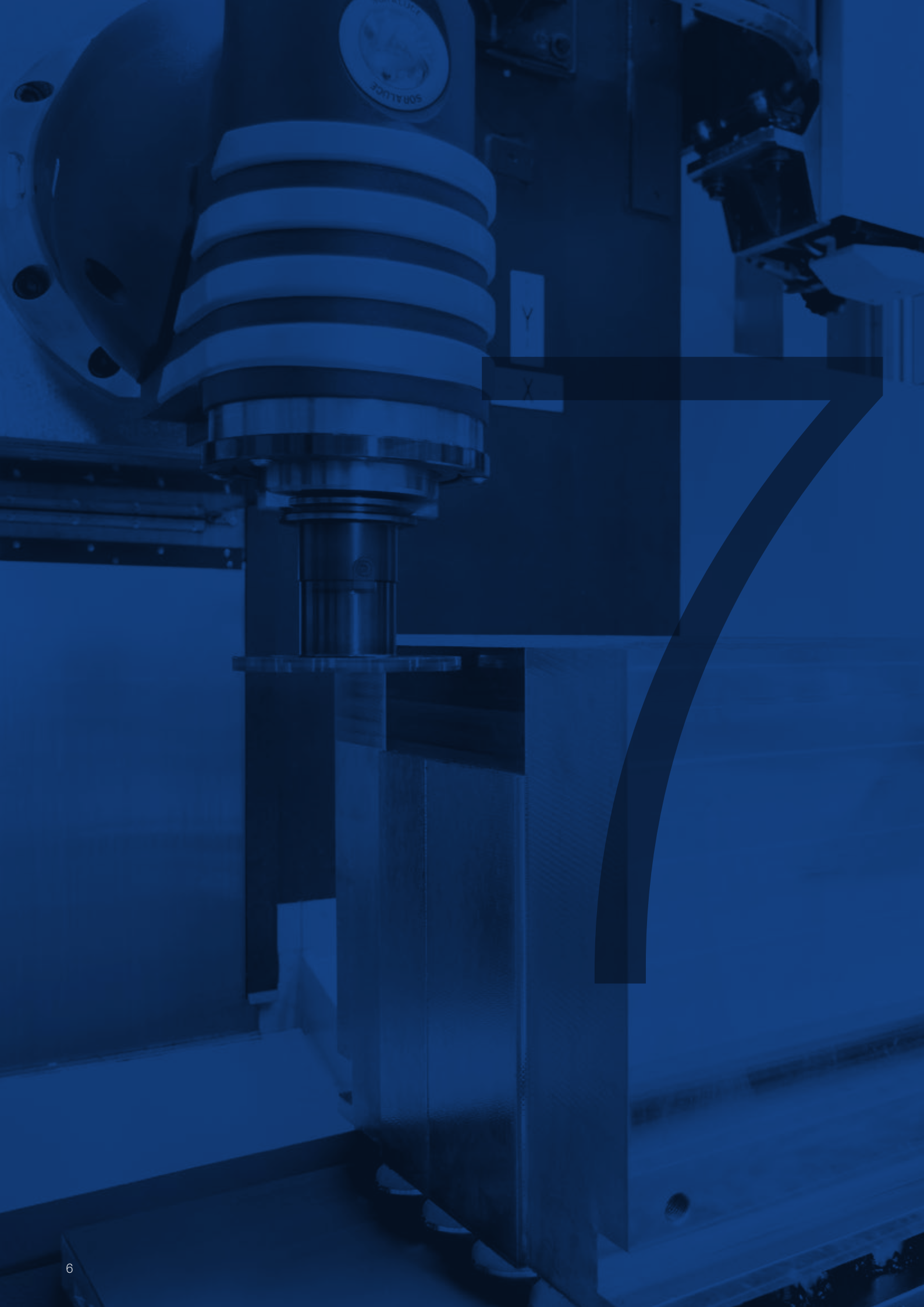

Seven reasons to choose Performance Line

01.

A winning combination

The most rigid and dynamic solution on the market

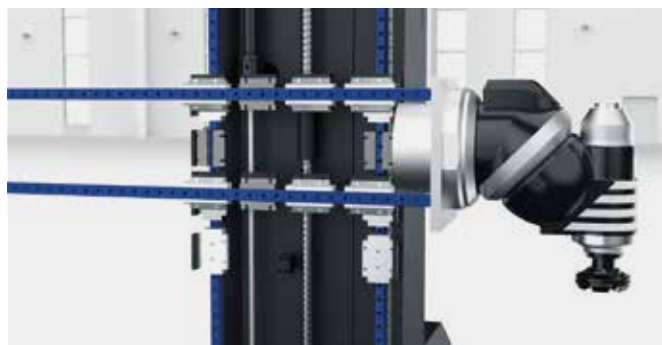

Full cast iron

Long term stability

Thermostability

- Expansion under control: quantity, speed, direction.
- Vibrations absorption, damping capacity.
- No need of electronic compensations.
- Best performance against temperature variations.
- Main structure: column, saddle, ram.

Linear guiding

Lifelong durability

- Soraluce is a pioneer in the use of linear guiding systems in large machines and heavyduty applications.
- Design proven since 1991.
- Lifelong durability > 10 years maintenance free at maximum performance.

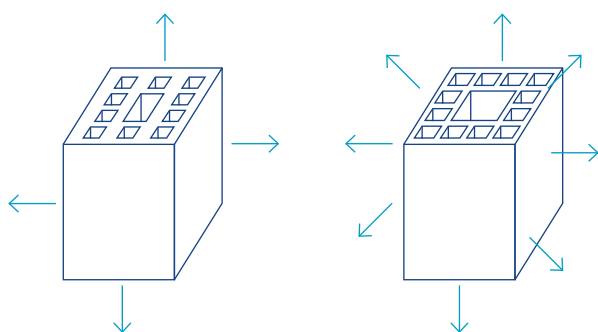

Cast iron

Fabricated steel

TOP BENEFITS	Linear guiding	Prismatic guiding	Hydrostatic guiding
Precision	↑↑↑	→	↑↑
Dynamics	↑↑↑	↓	↑↑
Maintenance free	↑↑↑	↓	↓
Loading capacity	↑↑↑	↑↑	↑↑
Thermal stability	↑↑↑	→	→
Sustainability	↑↑↑	↑	↓↓↓
Foundation cost saving	↑↑↑	↑↑↑	↓↓

Full cast iron

- Accuracy
- Stiffness
- Productivity

Linear guiding

- Best precision
- High dynamics

DAS+

- No chatter, best stock removal rate
- Optimized process thanks to real time vibration surveillance

Damping pads

- Stability during machining process
- Vibration absorption

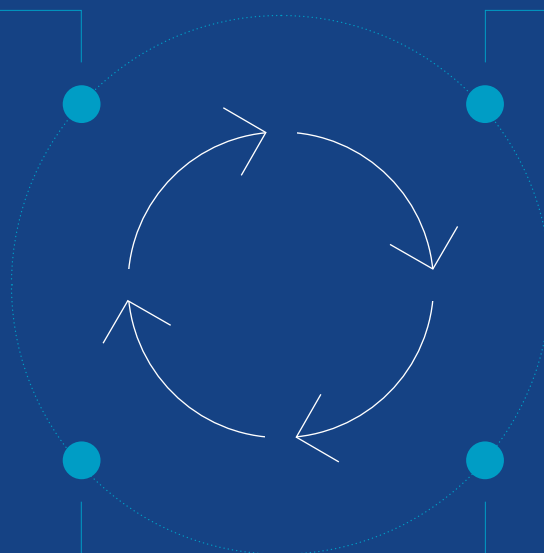

Damping pads

Great stability

- Own development of special damping pads combined with linear guides.
- Eliminates any vibration during machining processes.

DAS+

No chatter

Active damping system

- 100% cutting capacity through the complete workpiece volume.
- Reduced cycle time up to 45%.
- Increased productivity up to 300%.
- Improved surface quality.
- Extended tool life.
- Machine protected: long term precision as reduces machine's key components wear (ballscrew, guideway, gearbox, head), in both roughing and finishing operations.

How does DAS+ work?

DAS+ is a smart system which oversees the machining process and selects the best technological alternative to eliminate chatter:

- Active damping in the ram.
- Spindle speed tuning by automatic selection of optimum speed.
- Harmonic oscillation of spindle speed.

02.

Accuracy in the DNA

Increased effective stiffness

Design is conceived to obtain the best precision and rigidity. We keep maximum quality control of manufacturing and assembly until its final verification, using Smart 3D thermal compensation of the machine.

01 Stiffness forces triangle

- Compact saddle for best rigidity.
- The cutting forces are transferred directly from the cross axis roller bearings to the column, minimizing the deformation of the saddle.
- Special Soraluze saddle design with minimum distance between the ram and the column, providing excellent stability, precision and maximum cutting capacity.
- Ram saddle fully guided.

02 Torsion and deformation under control

- Provided by the best guiding system in the market.
- Straightness ensured through a perfect parallelism between guides supporting surfaces.
- Lateral ram torsion constrained by special ribbed design cast iron ram, all sides being solid.
- Full control over ram drop and flexion.

03 Minimum distance

- Short distance from the column to the tool, thanks to the arrangement of the ballscrew and counterweight system.
- Minimum machine overhang.

04 No compensation

- Ram drop under control without electronic compensation.



Torsion movement

Inline spindle motor

- High efficiency.
- Minimum noise level.
- High performance thanks to optimized power-torque curve.
- Full power at low rpm.
- Short distance between main motor and head transmission.

Compact-design transmission shaft.

Placed at the front of the ram close to the head.

Up to
32 kW

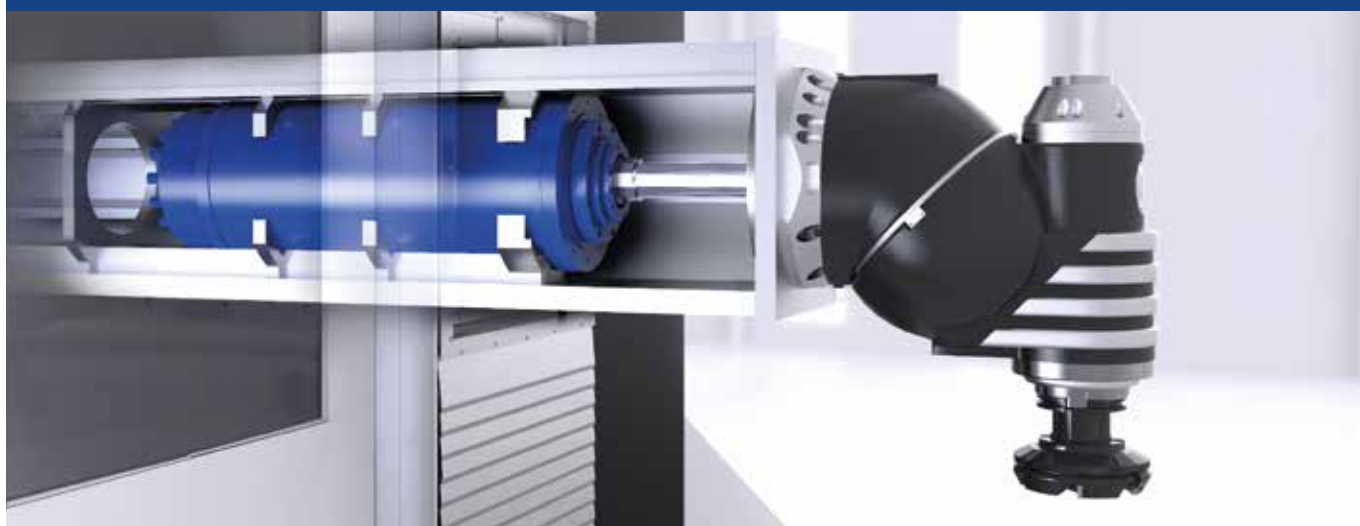

Best reliability

No belts, no reducers, neither long transmission bars.

Great precision

Best thermal stability provided by cooled inline motor.

Enhanced rigidity

Frontal assembly, all sides of the ram are solid.

Ease of maintenance

Quick exchange of the main spindle motor.

03.

Smart Technology



Automatic re-setting of head kinematics to increase accuracy. It compensates the head articulation positioning deviation for one particular position of the head.

+ ACCURACY



Eliminates any chatter that may arise during the machining process.

Machine protected: long term precision as reduces machine's key components wear.

+ PRODUCTIVITY
Patent no. EP 3017911



Eliminates chatter originated on either fixtures or workpieces.

+ PRODUCTIVITY
+ QUALITY

The logo for SORALUCE, featuring a stylized "S" icon and the text "SORALUCE" in a blue box.

SORALUCE



Energy save Package

+30% save
on energy consumption

You decide how and when the different components of the machine are switched on / off!

- Spindle
- Axes
- Machine power
- Control
- Lightning
- Air supply
- Hydraulic parts
- Warm-up program
- Calendar planning



Smart and automatic setting of defined cutting parameters according to actual machine power consumption.

30% time saved in roughing process!

+ PRODUCTIVITY



Cloud based software suite that enables seamless production information flow and maximizes machine performance.

+ PRODUCTIVITY

04.

Soraluce heads

More than
300
head models

Precision &
High performance

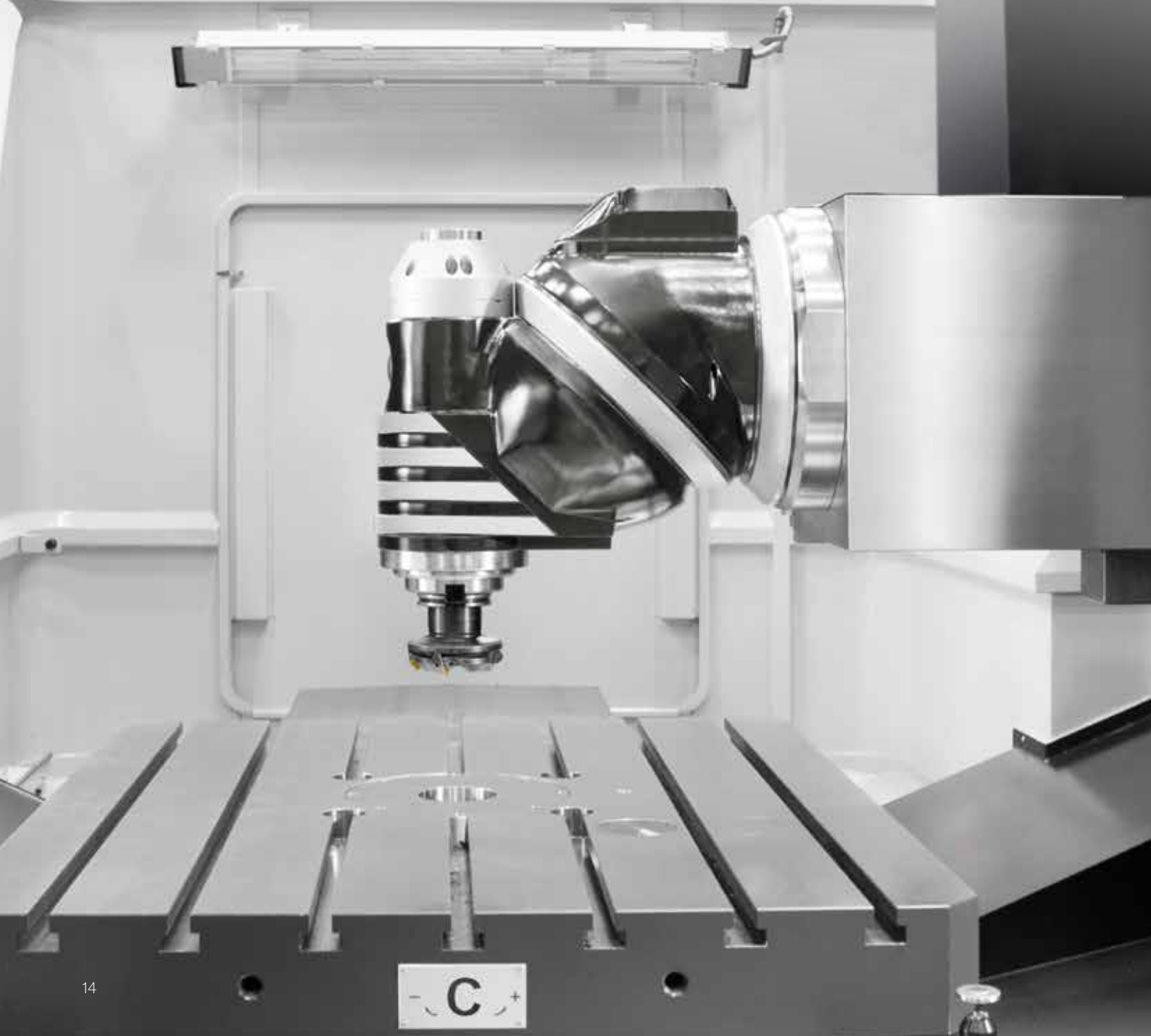

The most advanced head manufacturing center



In-house made



Head service hubs

- Your trusted service partner.
- Know-how directly from the manufacturer.
- Maintenance & repair.
- Spare head service available.

150
Spare heads available

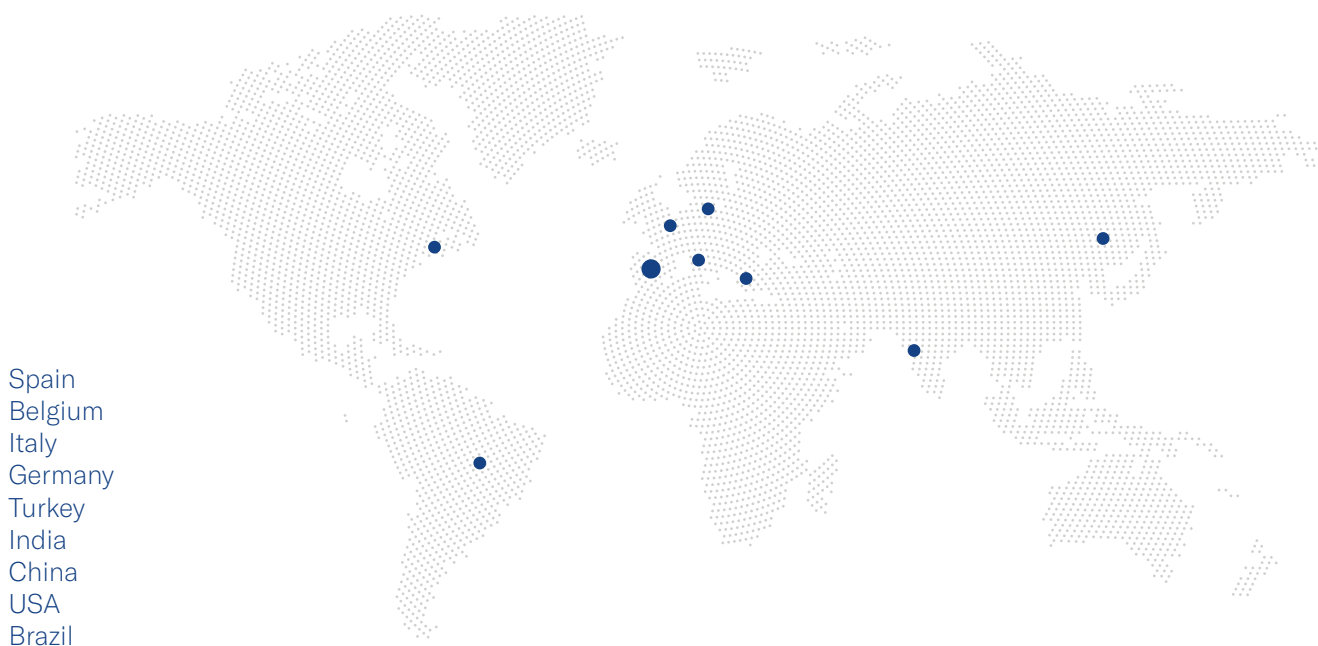

High Performance Heads

- Up to 32 kW (S1-100%).
- High speed up to 6000 / 7000 rpm.
- Automatic mechanical heads.
- Optimum accessibility thanks to reduced size.
- Robust performance.
- Highest reliability.
- Water cooling heads for maximum thermal stability.
- Air-oil lubricated heads, assuring perfect lubrication with minimum oil quantity and reduced heat generation.

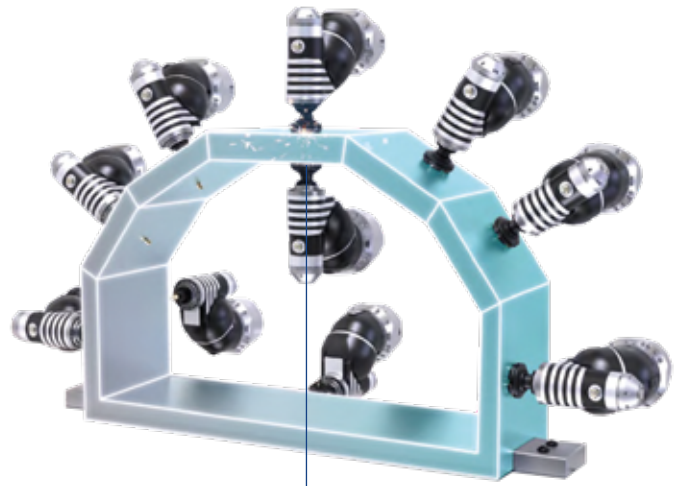

The power of indexing

Thousands of possibilities

Universal head

32 kW
 2.5° x 2.5° / 1° x 2.5° / 0.001° x 0.001°
 6000 / 7000 min⁻¹

Multitasking head

32 kW
 2.5° x 2.5° / 0.001° x 0.001°
 5000 / 6000 / 7000 min⁻¹

Orthogonal head

32 kW
 1° x 1°
 6000 / 7000 min⁻¹



Orthogonal Head

Compact design, conceived for machines with inline motor.

- Inverse machining capacity: up to -45°.
- No additional set-ups.
- Improved cycle time.
- Better finishing quality.
- Minimum manipulation.
- Full advantage of machine travel.
- Same distance from spindle to table during lateral and front milling.

High dynamics.

Maintenance friendly:
wear parts can be easily
replaced on site.

Precise machining results due
to high positioning accuracy.

Robust design.

Air-oil lubricated
gears; extended
operating hours.

High power and torque
allowing maximum cutting
capacity.

Water-cooled for best
thermal stability.

Customization: more than
300 head models at your
disposal.





05.

Multitasking

All in one: milling, turning, grinding and gear cutting in a single machine.



- Improved machining accuracy and overall part quality.
- Significant reduction in production lead time.
- Cost benefits: fewer fixtures, tools and labor requirements.
- Single machine investment for multiple processes.
- Optimized use of floor space.
- Machining of several morphologies, sizes and complexities.
- Improved precision due to minimum workpiece set-ups.
- Fewer operators involved in the machining process.

Milling & Turning Table		TAM	SAM
Table area	mm	Ø 1250	Ø 1000
Swing (max)	mm	Ø 2100	Ø 1500
Table capacity	kg	5000 (milling) 2000 (turning)	4000 (milling) 2000 (turning)
Turning spindle speed	min ⁻¹	400	
Turning spindle power	kW	65	60

*Floor type FA can be adapted to multitasking.

High Torque Multitasking Head

Head and spindle orientation at any angle.

- Standard tools, no adapter needed.
- Automatic tool changing system.
- Standard range, availability of spare parts.
- Ease of use thanks to specific positioning cycle.
- 32 kW
- Up to 611 Nm
- 5000 / 6000 / 7000 min⁻¹
- 2.5° x 2.5° / 0.001° x 0.001°

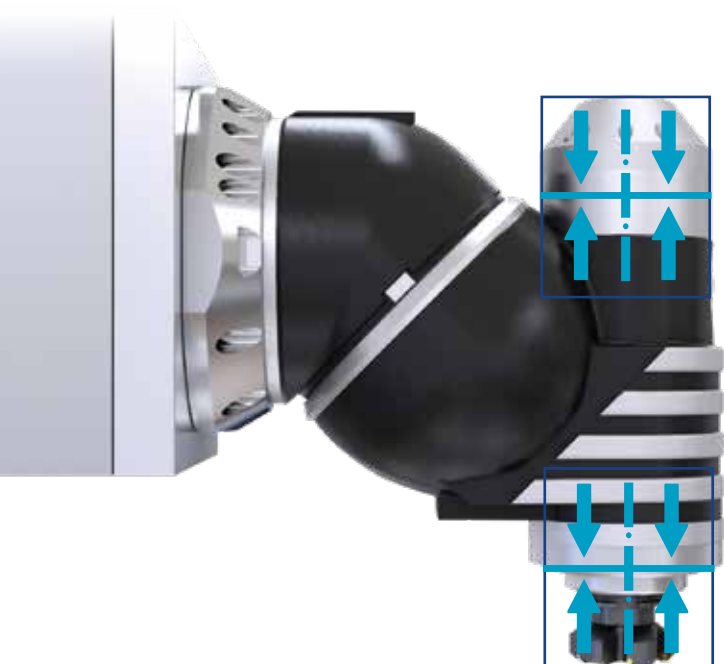

Mechanical transmission head with spindle clamping system: includes a clutch to clamp the spindle at any angle during turning operation.

The clamping system prevents bearing damage thanks to an internal retractable support ring.

Grinding capability



- Table mounted dressing unit.
- Wheel holder with integrated nozzle.
- Balancing unit.
- Full splash guarding.
- Fume extraction.
- Specific cooling system.
- Double protection for guideways and telescopics.
- Grinding cycles and functionalities by Soraluca Software Factory.

06.

Soraluce Software Factory

Smart HMI, Intelligent interface.

- Ergonomic and intuitive workspace.
- Soraluce's APPS available.
- Parallel work during NC program running.
- Minimized downtimes.
- Real time machine status.
- Energy consumption monitoring.
- Simplification of repetitive tasks.



01

Modular and robust;
configurable according
to customer's
requirements.

02

Own methodology;
complete integration,
approved in Soraluce.

03

Development of specific
custom cycles.

04

Capability for automated
system, flexibles
lines, centralized tool
magazines.



Softkeys &
Customized
masks



Manufacturing
cycles



Dynamic collision
monitoring



Advanced tool
management

07.

Digital services



Advanced Digital Services, based on the Soraluce Data System comprehensive monitoring platform:

Reportya

Regular customized reports.

FactoryConnect

Machine park monitoring and integrations with corporate management systems (ERP, MES, etc.).

Autocheck

Self-Assessment using Fingerprint benchmark parameters.

JobManager

Traceability of manufacturing orders, programs, tools and process incidences.

Emaintenance

Digital management of maintenance tasks.

OEEMonitor

Availability & Performance & Quality parameters calculation.

Meet
the machines



TA

Bed type milling machine

SORALUCE TA is much more than a machining center providing higher working volume, power, torque and cutting capacity.

Designed to offer optimum rigidity and mechanical stability, with the best ergonomic, accessibility and safety to operators.

Choose the configuration of your TA



TA
Standard table



TAD | TAM
Rotary milling | turning table



TAD | TAM
Integrated rotary milling | turning table

Much more than a machining center

	Soraluce milling machine	Machining center
Working volume	↑	↓
High power	↑	↓
High torque	↑	↓
Cutting capacity	↑	↓
Deep drilling	↑	↓
Ergonomic	↑	↓
Compact	↑	↓

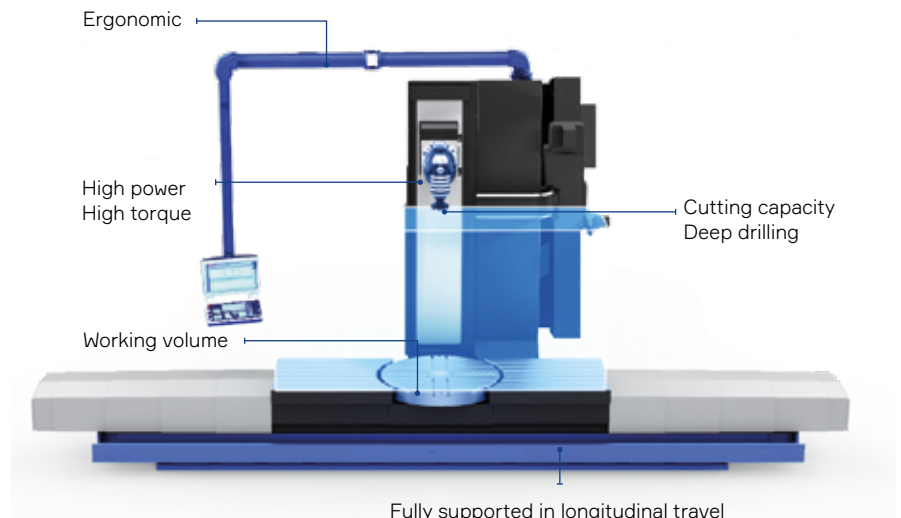

TA

Best ergonomics

Standard peripheral or complete splash guarding:

- Easy front & rear access to work area.
- 2 sliding frontal doors.
- Extra back door.
- Sides opening for long workpiece loading / unloading tasks.
- Extra thickness for long-term resistance.
- Glass windows for long-term clear vision.
- Fumes extraction systems (as option).
- Automatic door opening (as option).
- CCTV camera (as option).
- Extra LED lighting (as option).



Choose the configuration of your table TAD | TAM

Swing (max.) Ø 2100 mm



Rotary table for milling (squared)



Rotary milling | turning table (round)



Integrated rotary milling | turning table (located in the center of the table)



Integrated rotary milling | turning table (located in the right lateral side of the table)

TAD Integrated B-axis rotary table

4 or 5 axes continuous machining

- Universal automatic indexing head, 4 axes (standard).
- Vertical high-speed head, 4 axes.
- Vertical high speed continuous positioning head (torque motor, C-axis), 5 axes.
- Universal automatic indexing head with electrospindle attachment, 4 + 2 axes.

- Five-sided machining.
- Ease of use with specific rotary table cycles.
- High accuracy thanks to the table center measuring and correction.
- Permanent table rotation compensation.



Ergonomics & Easy maintenance

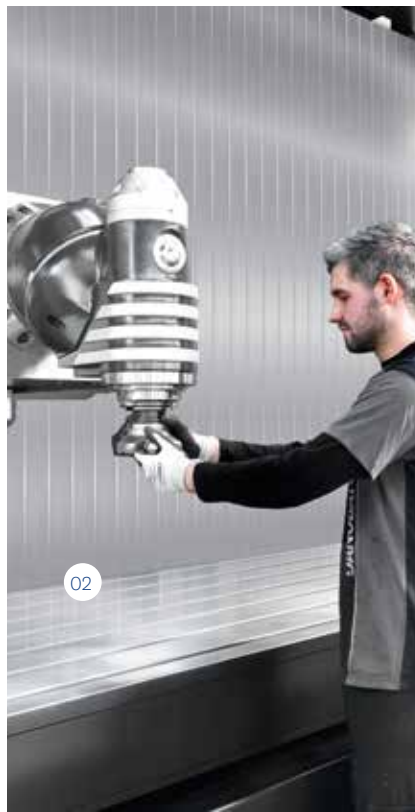

01

Tool loading/unloading with machine in operation.

02

Accessible and spacious work area.

03

Working area perfectly lightened.

04

Flexible control panel arm: CNC control at the front or rear-side of the machine.

05

Protection of the critical areas of the equipment.

06

Wide glass surfaces.

07

Visible gauges and levels.

08

Accessible intervention areas to ease maintenance tasks.

09

Sliding doors and windows to prevent dismantling of panels.

Features TA

Technical characteristics

Common features TA TAD TAM			
Longitudinal traverse "X" axis	mm	2500	3500
Vertical traverse "Z" axis	mm	1500	
Cross traverse "Y" axis	mm	1200	
Spindle power	kW	32 (S1)	
Spindle speed range	min ⁻¹	6000 / 7000	
Rapid traverse	mm/min	Y/Z: 35000 X: 30000	
Tool magazine	No. Tools	40 / 60	
		TA25	TA35
Table area	mm	2700 x 1000	3700 x 1000
Table capacity	kg	6700	9250
		TAD25	TAD35
Table area	mm	1000 x 1000 / 1250 x 1250 / 1500 x 1500	Ø 1000 / Ø 1250 3500 x 1050
Swing (max)	mm	2100	
Table capacity	kg	7000	9250
		TAM25	TAM35
Table area	mm	Ø 1250	Ø 1250 (turning) 3500 x 1050 (milling)
Swing (max)	mm	2100	
Table capacity	kg	5000 (milling) 2000 (turning)	
Turning spindle speed	min ⁻¹	400	
Turning spindle power	kW	65	

Technology at your disposal

■ Basic machine ■ Optional

	TA	TAD	TAM
Full cast iron	■	■	■
Linear guiding & Damping Pads	■	■	■
Inline spindle motor	■	■	■
DAS+	■	■	■
Multitasking	-	-	■
Complete splash guarding	■	■	■
Soraluce Smart HMI	■	■	■

Set & Go

Less expensive foundation.
Easy transport & installation.

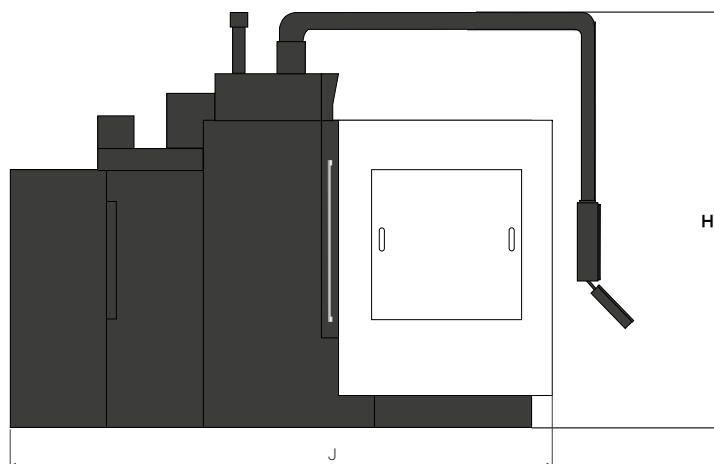
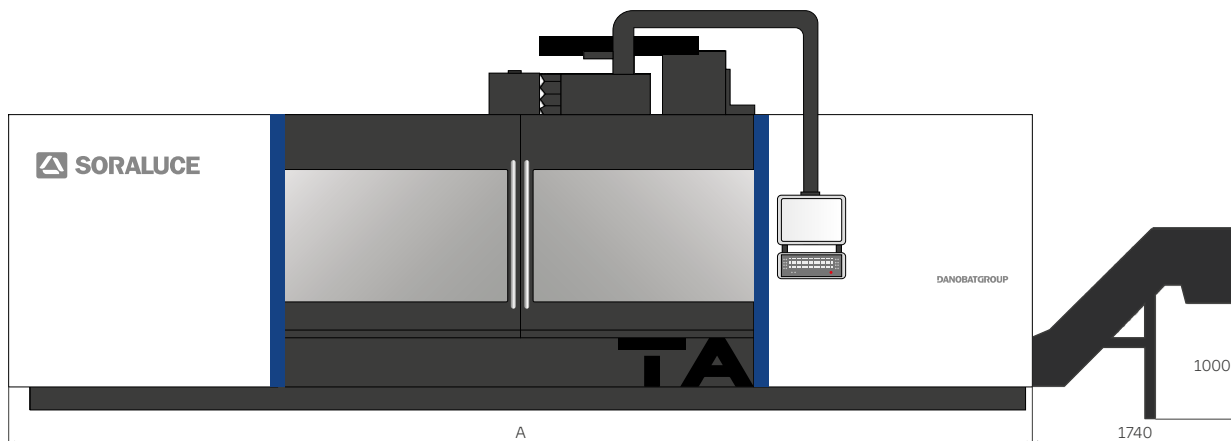

TA Layout	X	Z	Y	A	H	J
TA25	2500	1500	1200	6760	3720	4600
TA35	3500			8760		
TAD25	2500	1500	1200	5960	3790	5200
TAD35	3500			8760		
TAM25	2500			5960		
TAM35	3500			8760		



FA

Floor type milling machine

SORALUCE FA offers great versatility with multiple configurations available, customizing working area to customer's needs: boosting productivity rates.

Pendulum working

Choose the configuration of your FA

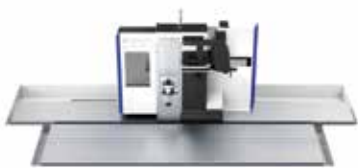

Basic configuration
Floor type

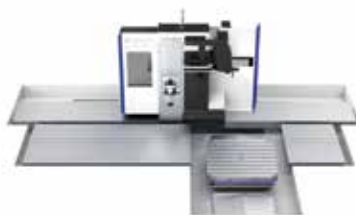

Flexible configuration
Minimum workplace set-ups



Multitasking configuration
Milling and turning workspaces

Monoblock structure



+ Rigidity:

- Column and longitudinal carriage in one piece for maximum stability.
- The best behavior against torsion and bending.

Column size 3 times larger than box-in-box concept.

FA

Driving system

Reliable

Double rack and pinion system in the longitudinal axis. The best existing solution for long travel axes.

Dynamic

Up to 35,000 mm/min.

Long term accuracy

- No backlash, no wear.
- Highest surface quality.

Maintenance free

Automatic lubrication of the rack and pinion system.



In & Out

Portable rotary table



Duplex machine

Machining with two simultaneous spindles



Ergonomic

Table at operator's height

Features FA

Technical characteristics

		FA30	FA40	FA50	FA60	FA70	FAXX
Longitudinal traverse "X" axis	mm	3000	4000	5000	6000	7000	as per request
Vertical traverse "Y" axis	mm	1500					
Cross traverse "Z" axis	mm	1200					
Spindle power	kW	32 (S1)					
Spindle speed range	min ⁻¹	6000 / 7000					
Rapid traverse	mm/min	35000					
Tool magazine	No. Tools	40 / 60					

Technology at your disposal

■ Basic machine ■ Optional

	FA
Full cast iron	■
Linear guiding & Damping Pads	■
Inline spindle motor	■
Monoblock	■
DAS ⁺	■
Multitasking	■
Soraluce Smart HMI	■

With or without pit

Ground level



Pit



Set & Go

Less footprint in the workshop. Less expensive foundation. Easy transport & installation.

FA

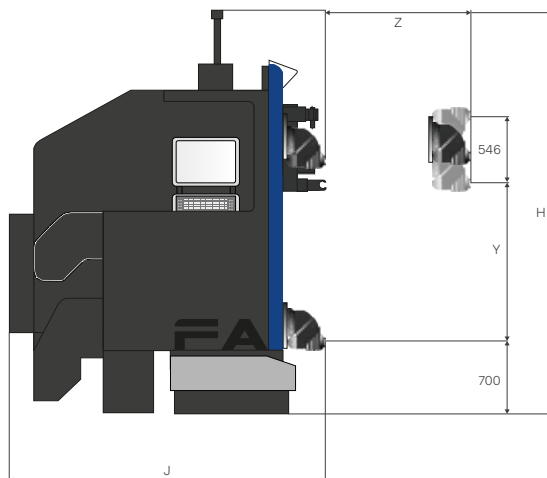
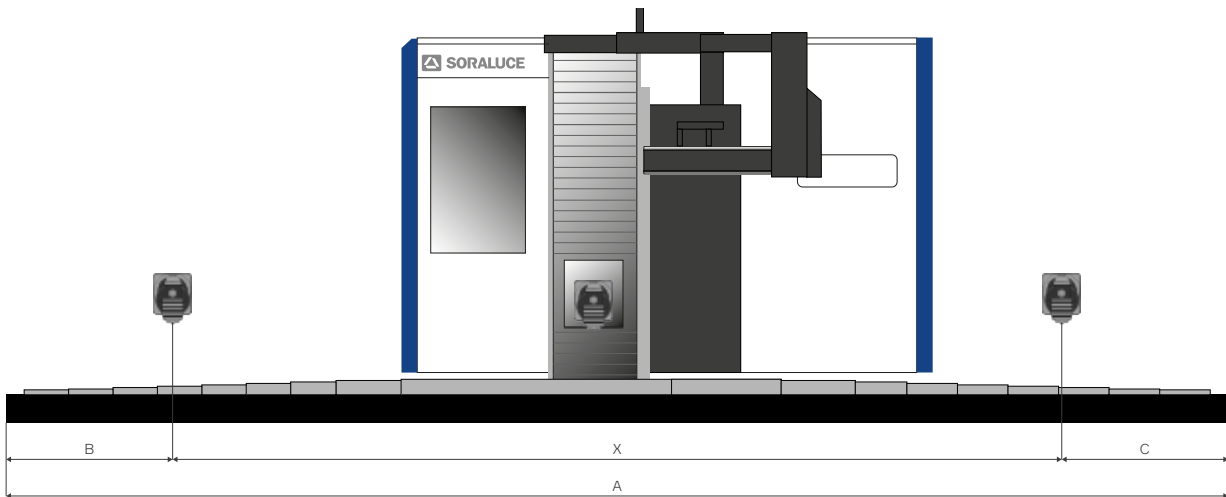

FA Layout	X	Y	Z	A	B	C	H	J
FA30	3000	1500	1200	7480	1590	2890	3790	3120
FA40	4000			8480				
FA50	5000			9480				
FA60	6000			10480	1730	3040		
FA70	7000			11780				
FA80	8000			13080	1880	3390		
FA100	10000			15480				
FA120	12000			18000	2350	3650		
FA140	14000			20000				

Dimensions in mm.



SA

Fixed table travelling column machines

SORALUCE SA has a unique machine architecture for the best stability. With a compact design, it is a machining center with mechanical head, offering high dynamics in all axes and great ergonomics, accessibility and safety to operators.

Pendulum working

Choose the configuration of your SA



SA

Fixed table



SAD | SAM

Fixed table and integrated milling
or milling & turning table



SAD | SAM

Fixed table and integrated two milling
or milling & turning tables

Monoblock structure

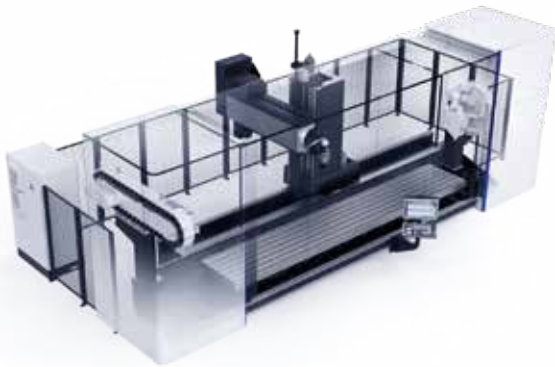

+ Rigidity:

- Column and longitudinal carriage in one piece for maximum stability.
- The best behavior against torsion and bending.

Column size 3 times larger than box-in-box concept.

Driving system

Reliable

Double rack and pinion system in the longitudinal axis. The best existing solution for long travel axes.

Dynamic

Up to 35,000 mm/min.

Long term accuracy

- No backlash, no wear.
- Highest surface quality.

Maintenance free

Automatic lubrication of the rack and pinion system.

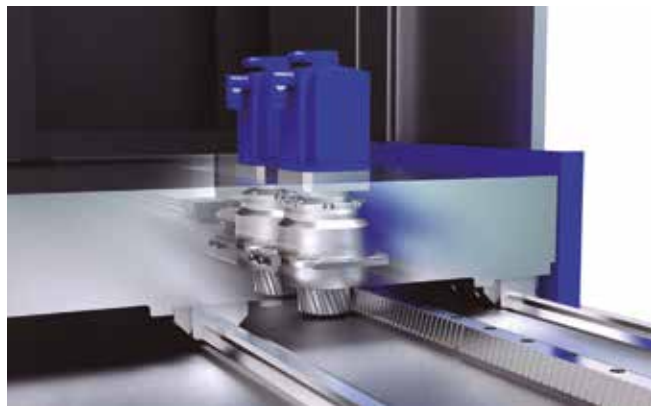

Much more than a machining center

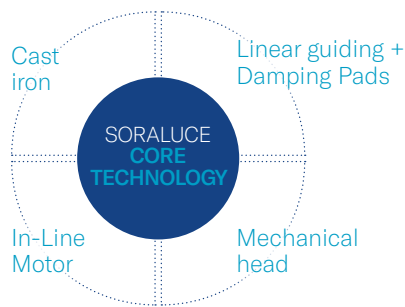

TOP BENEFITS	Soraluce technology	Vertical Spindles	Prismatic guiding	Gearbox	Welded structure
Precision	↑↑↑	↑↑↑	→	↑	→
Maintenance free	↑↑↑	↑	↓	↓	
Productivity (less set-up)	↑↑↑	↓			
Thermal stability	↑↑↑	↑↑↑	→	↓	↑
Sustainable	↑↑↑	↑↑↑	→	↑	
Cutting capacity	↑↑↑	↓	↑↑	↑↑↑	↑
Damping capacity	↑↑↑		↑		↓

Best ergonomics

- Complete splash guarding.
- Complete front workpiece access.
- Workpiece at operator's height.
- CNC on a sliding guide in front of the machine.
- Integrated swarf collection.
- Pendulum working.

Ground level installation



SA

Features SA

Technical characteristics

Common features SA SAD SAM				
Longitudinal traverse "X" axis	mm	4000	5000	6000
Vertical traverse "Z" axis	mm	1500		
Cross traverse "Y" axis	mm	1200		
Table area	mm	4000 x 1000	5000 x 1000	6000 x 1000
Spindle power	kW	32 (S1)		
Spindle speed range	min ⁻¹	6000 / 7000		
Rapid traverse	mm/min	35000		
Tool magazine	No. Tools	40 / 40+24		
		SA40	SA50	SA60
Table capacity	kg	8000	10000	12000
		SAD40	SAD50	SAD60
Integrated rotary table	mm	Ø 1000		
Swing (max)	mm	1500		
Table capacity	kg	4000		
		SAM40	SAM50	SAM60
Integrated turning table	mm	Ø 1000		
Swing (max)	mm	1500		
Table capacity	kg	4000 (milling) 2000 (turning)		
Turning spindle speed	min ⁻¹	400		
Turning spindle power	kW	60		

Technology at your disposal

■ Basic machine ■ Optional

	SA	SAD	SAM
Cast iron	■	■	■
Linear guiding & Damping Pads	■	■	■
Inline spindle motor	■	■	■
Monoblock	■	■	■
DAS+	■	■	■
Multitasking	-	-	■
Complete splash guarding	■	■	■
Soraluce Smart HMI	■	■	■

Set & Go

Less footprint in the workshop. Less expensive foundation. Easy transport & installation.

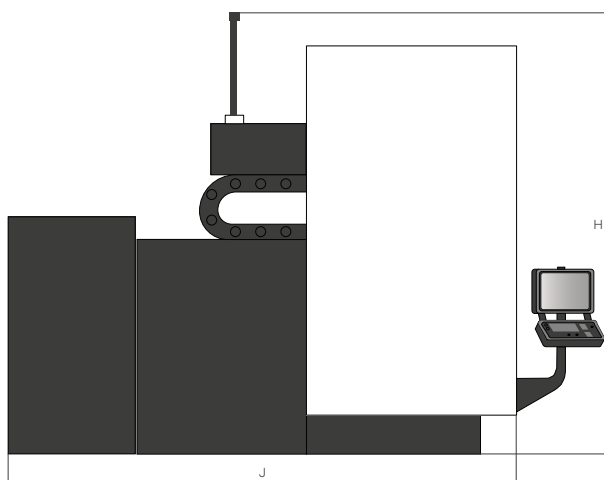
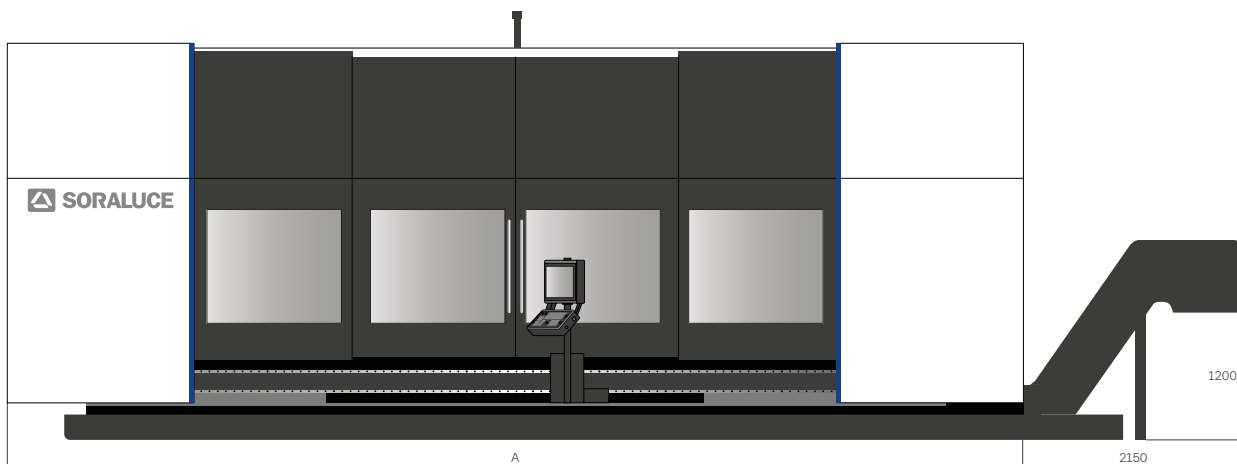

SA

SA Layout	X	Z	Y	A	H	J
SA40	4000	1500	1200	7800	4150	4770
SA50	5000			8800		
SA60	6000			9800		
SAD40	4000			7800		
SAD50	5000			8800		
SAD60	6000			9800		
SAM40	4000			7800		5370
SAM50	5000			8800		
SAM60	6000			9800		

Dimensions in mm.

Applications

FA
Capital Goods



FA
Capital Goods



TAD
Aerospace / Landing gear



FA
Industrial vehicles / Booms and frames

TAM
Engine



TAD
Molds



FA
Machine tools



There is only one first

Soraluce

Osintxu Auzoa - E-20570 Bergara (Gipuzkoa) - Spain
+34 943 76 90 76

www.soraluce.com

DANOBATGROUP

