

Vertical CNC Lathes

V series

Vertical CNC Lathes

V40R / V100R

Vertical Twin-Spindle CNC Lathe

2SP-V40



Vertical CNC Lathes
V series

V40R / V100R Vertical CNC Lathes

2SP-V40 Vertical Twin-Spindle CNC Lathe

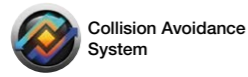

For increased productivity of medium and large flanges
Providing stable machining of thin and odd-shaped
workpieces



V40R



V100R



2SP-V40

Photographs used in this brochure may show optional equipment.

Stable accuracy

- ◆ Powerful machining of medium to large cubic and odd-shaped workpieces
- ◆ The box-type base and column make a highly dependable, highly rigid structure
- ◆ Workpiece deadweight pressed on vertical chuck helps stabilize machining

Highly rigid construction

- A strong, square column is positioned on a large, rigid base with good damping properties, and a highly rigid, reliable structure with wide box ways on both the X and Z axes is used.
- Smooth, stable feeds are achieved during low- to high-speed cutting with a counterbalance not affected by feed rate changes.

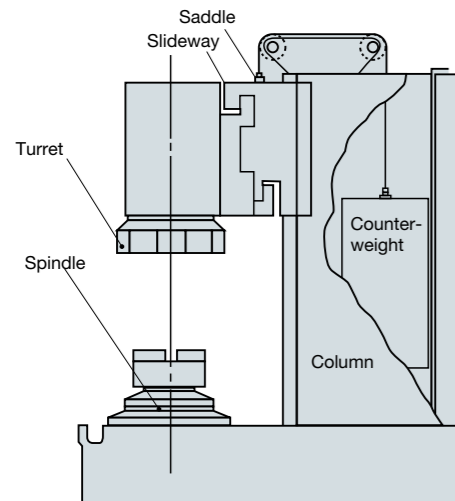

Turret

- Large 12-station turret has adequate space for easy and also permanently set tooling arrangements.
- The large-diameter coupling enables high accuracy indexing and powerful heavy-duty cutting with strong hydraulic clamps.

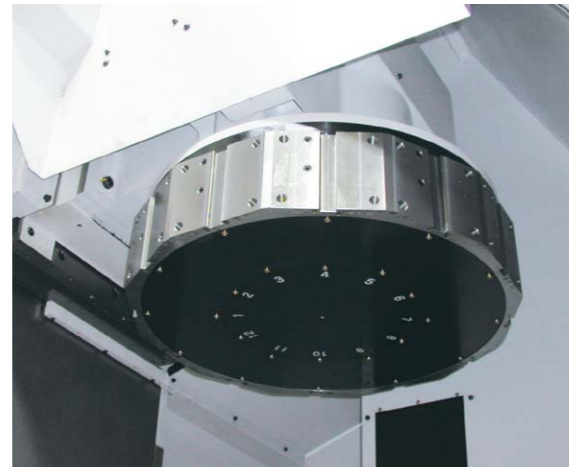

V100R

Stable machining achieved with workpiece deadweight sitting tight on chuck

- The workpiece deadweight itself helps provide a firm seat on the chuck reference surface. Without excessive workpiece restraint, distortion and pressure marks can be prevented to achieve highly accurate machining of thin to large and heavy workpieces.

Manual part load/unload, without holding it, is also easy for irregularly shaped workpieces that require clamps.

Workpiece deadweights sit firmly on chuck reference surface

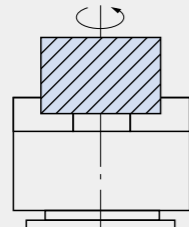

Simple to load/unload odd-shaped workpiece

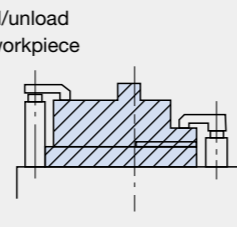

Powerful machining

- ◆ Using motors with wide constant-power ranges
- ◆ Headstock with flange construction to minimize effects of thermal deformation and vibration

Spindle

- The headstock has a flange construction and is solidly fixed to a box-type base. This minimizes the effects of thermal deformation and vibration.
- A powerful motor with a wide constant-power range is used for the spindle. Combining this with a big bore spindle enables powerful heavy-duty cutting.

	V40R/2SP-V40	V100R
Spindle type	A2-8	Flat ø380 (14.96)
Outside diameter	ø120 (4.72)	ø200 (7.87)
Inside diameter	ø77 (3.03)	ø110 (4.33)

mm (in)



V40R/2SP-V40

- Spindle speed 2,500 min⁻¹
- Maximum output 22/18.5 kW (30 min/cont) (30/25 hp)
- Maximum torque 657/552 N-m (30 min/cont) (483/407 ft-lbf)

V100R

- Spindle speed 1,250 min⁻¹
- Maximum output 45/37/30/22 kW (5/10/30 min/cont) (60/50/40/30 hp)
- Maximum torque 3,870/3,182/1,377/1,010 N-m (5/10/30 min/cont) * (2,846/2,340/1,013/743 ft-lbf)

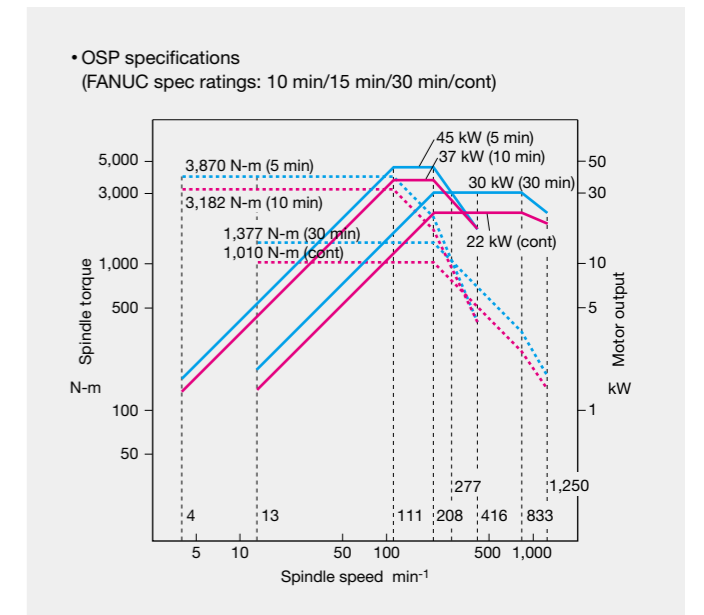
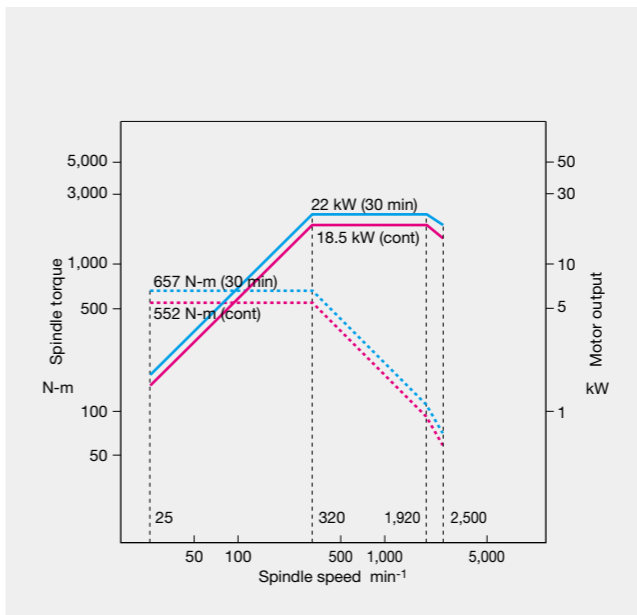

Maintenance and operability

- ◆ Rear or side chip conveyor to meet shop requirements
- ◆ Base designed for smooth chip flow
- ◆ Ergonomic design includes easy access to the chuck, and front-skirt and swiveling operation panels convenient for up-close jobs

Huge reduction in setup time with Touch Setter (auto tool compensation) (Optional)

- Shorter tool compensation setting time is possible
- Quick and accurately set tool compensation by any operator
- Highly accurate and agile 4-way touch sensor able to measure various tool angles

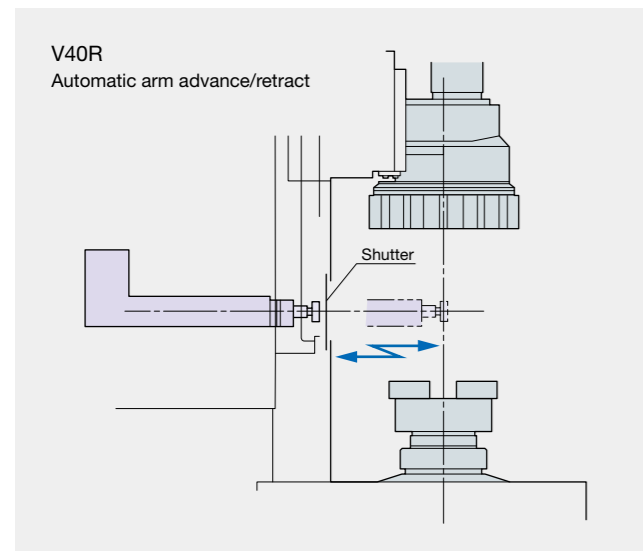

Outstanding chip disposal

- Machine base designed for smooth chip flow—outstanding chip discharge
- Thorough chip disposal measures with shower/chip flow coolant as standard equipment.

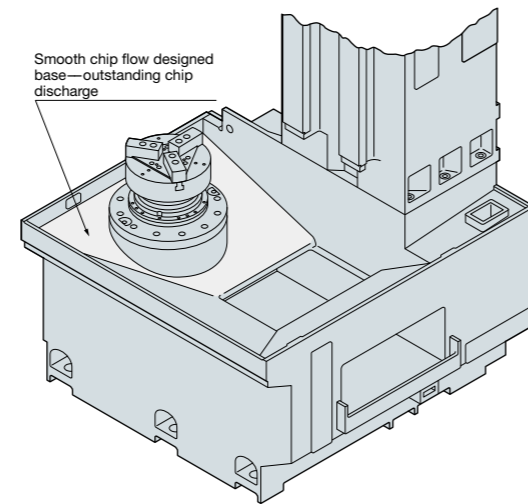

Chip conveyor (Optional)

- Chip discharge in any direction to match shop layout—side or rear disposal.
- Variety of chip conveyors to match type of workpiece material.

Chip conveyor types and applications

Type	Hinge	Scraper	Magnet scraper	Hinge + Scraper*
Application	● Steel	● Casting	● Casting	● Steel, casting, nonferrous metal
Features	● General use	● Magnetic scraper more effective for sludge disposal ● Easy maintenance ● Blade scraper	● Effective with sludge ● Not suited for nonferrous metals	● Filtration of long and short chips and coolant
Shape				

Note: Machine platform may be necessary depending on the type of chip conveyor.

* With drum filter

Operations done from machine front

- Outstanding spindle accessibility, simple two-handed load/unload of large-diameter workpieces.
- Front-skirt operation panel convenient for up-close jobs.
- Easy changeover with swiveling pendant operation panel.
- Chuck pressure adjustments can also be easily done from front of machine.
- Completely independent operation on right/left spindles (2SP-V40).



Convenient front-apron operation panel

Outstanding accessibility

Access	L	L1	H
V40R/ 2SP-V40	548 (21.57)	340 (13.39)	960 (37.80)
V100R	860 (33.86)	440 (17.32)	1,170 (46.06)

mm (in)

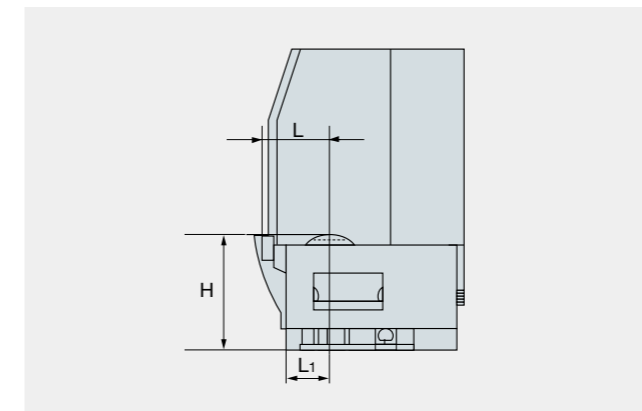

Machine side view

Jib cranes (Optional)

- Machine mounted manual chain hoist part loader/unloader for easy lifting of heavy-workpieces.

Maximum lifting weight	100 kg (220 lb), 200 kg (440 lb) (V40R, 2SP-V40 are 100 kg (220 lb) only)
------------------------	--

- Workpiece can easily be mounted on chuck reference surface with high-/low-speed switch.
- Workpiece lifting hook preparations required by the end user.
- For stable surface quality, refrain from operating a jib crane during a cutting process.



High productivity

- ◆ Zero WIP (work in progress) with process-intensive machining.
- ◆ Raise productivity with multitasking applications.

Two-spindle lathe (2SP-V40): High productivity with double the performance on one machine

- Because of the separate L/R structures, machining vibration does not affect the other spindle.

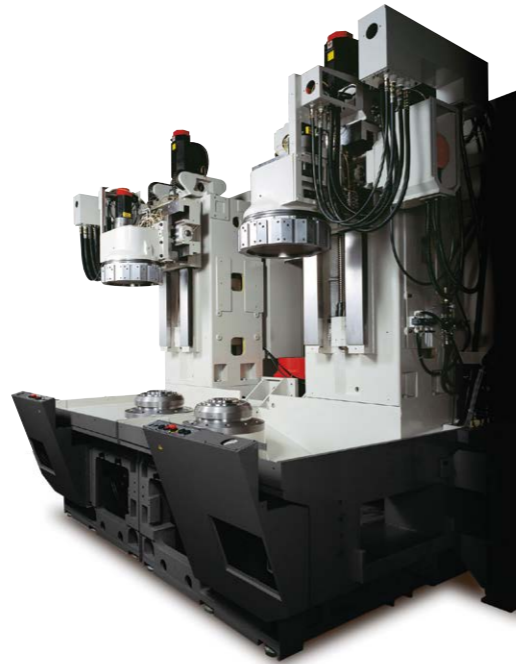

Multitasking specifications provide powerful process-intensive machining to deal with a wide range of production configurations (Optional)

Turning + drill / end mill operations all done completely on one machine

- Improved machining accuracy
- Improved productivity with process-intensive machining

Multitasking

	Items	Unit	V40R 2SP-V40	V100R
Milling tool spindle	Controlled axes		X, Z, C axes	
	Turret configuration		Multitasking V12	
	No. of M tools		6 (Turret station no. 1, 3, 5, 7, 9, 11)	
	Spindle speed	min ⁻¹	2,000	3,000
	Attached bore collet	mm (in)	ø32 (1.26)	
	Motor	kW (hp)	3.5 (4.7) [4 (5.3)]	3.5 (4.7) [5.5 (7.3)]
C axis	Minimum input increment	deg	0.001	

- []: FANUC specifications
- Multitasking specs available for one or both spindles.



Rotary tool unit mounts

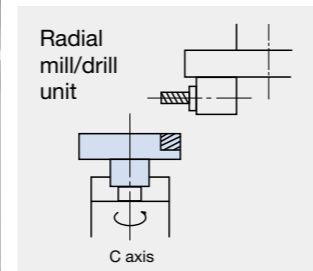
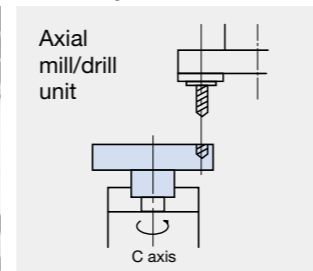

Maximum 6 M tools/turret

Automation, laborsaving equipment

Workpiece push-up and ejector devices (Optional)

Semi-auto loader handles relatively large workpieces safely and reduces operator burden

- Features**
- 1. Lifting workpieces from the conveyor not required**
Simply push them on the roller conveyor
 - 2. Safe handling of large workpieces**
Considerably reduces operator burden
 - 3. Machining accuracy assurance**
The operator simply mounts the workpiece and after check it.

Optional for V40R, 2SP-V40

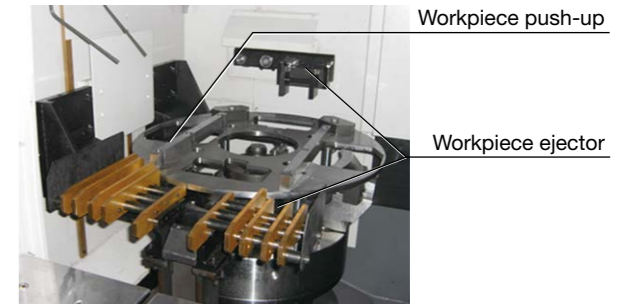

- Manual push-in, automatic chucking of blanks
- Automatic finished workpiece ejector
- Accommodates thin workpieces (chucked wall less than 40 mm)
- Workpiece weight: 20 kg (approx)

Robot system (Optional)

Fully automatic workpiece handling with robot traveling on gantry beam

- Longer robot travels—ideal for linking multi-operation runs.
- Use of gantry robot means spindle access is good and setup changes are simple.

Optional for V40R, 2SP-V40

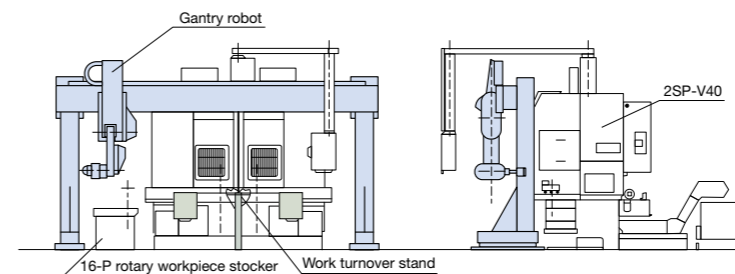

Machine Specifications

		Item	Unit	V40R/2SP-V40	V100R
Capacity	Max turning diameter	mm (in)		ø400 (15.75)	ø1,000 (39.37)
	Max swing diameter	mm (in)		ø500(19.69)	ø1,250 (49.21)
	Max turning length	mm (in)		450 (17.72)	890 (35.04)
	Max chuck size	mm (in)		ø450 (17.72)	ø1,010 (39.76)
	Max workpiece weight*1	kg (lb)		300 (660)	1,200 (2640)
				400 kg/800 min ^{-1*2}	2,000 kg/200 min ^{-1*2}
Travel	X axis	mm (in)		265 (10.43)	565 (22.24)
	Z axis	mm (in)		450 (17.72)	890 (35.04)
Spindle	Speed	min ⁻¹		25 to 2,500	13 to 1,250
	Speed ranges			Infinitely variable	2 auto ranges (2 range motor coil switching)
	Type of nose			A2-8	Flat ø380 (ø14.96)
	Front bearing dia	mm (in)		ø120 (4.72)	ø200 (7.87)
	Bore dia	mm (in)		ø77 (3.03)	ø110 (4.33)
	Floor to spindle nose	mm (in)		960 (37.80)	1,170 (46.06)
	Spindle support			2-point roller bearing	
	Turret	Turret type		V12	
Turret	OD tool shank dimensions	mm (in)		□25 (1)	□32 (1-1/4)
	ID tool shank diameter	mm (in)		ø40, ø50 (1.57, 1.97)	ø40, ø50, ø63 (1.57, 1.97, 2.48)
Feed Axis	Rapid traverse	X axis	m/min (fpm)	24 (78.74)	
		Z axis	m/min (fpm)	24 (78.74)	
Motor	Spindle drive	OSP	kW (hp)	22/18.5 (30/25) (30 min/cont)	45/37 (60/50) (5 min/10 min)
		FANUC	kW (hp)	22/18.5 (30/25) (30 min/cont)	45/37 (60/50) (10 min/15 min)
Machine Size	Required floor space	mm (in)		1,705 × 2,788 (67 × 110)	2,735 × 3,445 (107 × 135)
	(width × depth) (2SP-V40)	mm (in)		2,970 × 2,738 (116 × 108)	—
	Machine height	mm (in)		3,040 (119)	OSP: 3,510 (138) FANUC: 3,565 (140)
	Machine weight	kg (lb)		7,200 (15,840)	14,000 (30,800)
	(2SP-V40)	kg (lb)		14,000 (30,800)	—
CNC Control				OSP-P300LA, FANUC 31i-B	

*1. With chuck *2. Maximum workpiece load and spindle speed when spindle speed is restricted

Standard Specifications and Accessories

		V40R/2SP-V40	V100R
Spindle		A2-8, 25 to 2500 min ⁻¹	Flat ø380, 13 to 1250 min ⁻¹
	OSP	22/18.5 kW (30 min/cont)	45/37 kW (5 min/10 min)
	FANUC	22/18.5 kW (30 min/cont)	45/37 kW (10 min/15 min)
Turret		V12	
● Standard Accessories			
Coolant system	Coolant tank	290 L (76.6 gal)	450 L (118.9 gal)
	(2SP-V40)	450 L (118.9 gal)	—
	Pump motor (2SP-V40 with 2 sets)	0.25 kW	
	Shower/chip flusher (2SP-V40 with 2 sets)	0.55/0.37 kW (60/50 Hz)	
Full enclosure shielding		○	
Jack screws, foundation pads		○	
Work lamp		○	
Hand tools		○	
● Standard Specifications			
Front door interlock		○	
Lubrication monitor		A-1	
Chuck open/close push button switch		○	

Tooling System

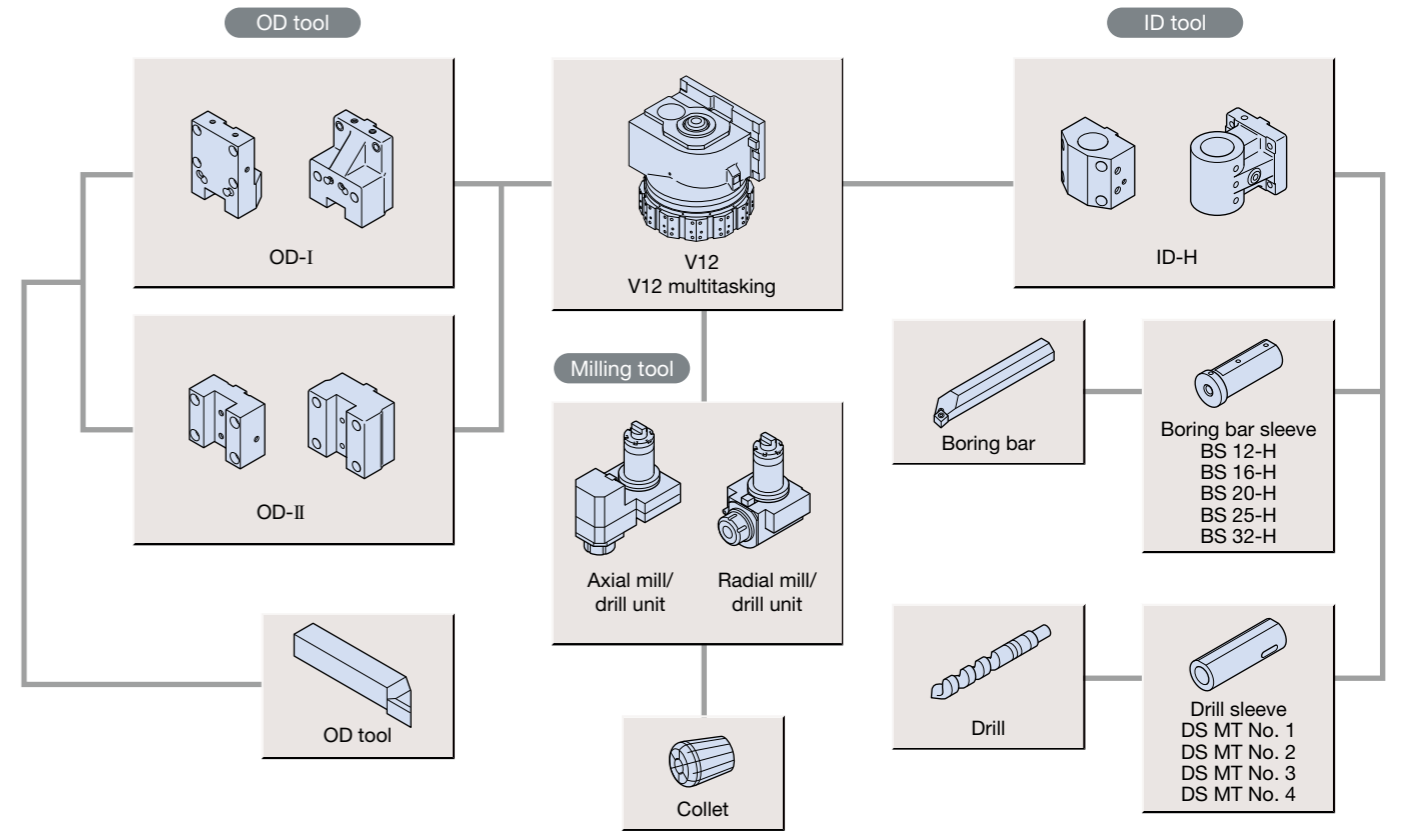

*Illustration and actual shape may differ with V40R, 2SP-V40, V100R, respectively, as well as with turning turret and multitasking turret.

Tooling Kits (pcs/kit)

	V40R		2SP-V40				V100R	
	Turning turret	Multitasking turret	Turning + Turning	Turning + Multitasking	Multitasking + Multitasking		Turning turret	Multitasking turret
OD-I 25	6	—	12	6	—	OD-I 32	6	3
OD-I 25 M/D*	—	3	—	3	6	OD-II 32	3	3
OD-II 25	3	—	6	3	—	ID-H50	6	3
OD-II 25 M/D*	—	3	—	3	6	BS 32-H50	2	2
ID-H40	6	—	12	6	—	Axial mill/drill unit	—	2
ID-H40 M/D*	—	3	—	3	6	Radial mill/drill unit	—	2
BS 12-H40	2	2	4	4	4			
BS 16-H40	2	2	4	4	4			
BS 20-H40	2	2	4	4	4			
BS 25-H40	2	2	4	4	4			
DS MT No. 1-H40	1	1	2	2	2			
DS MT No. 2-H40	1	1	2	2	2			
DS MT No. 3-H40	1	1	2	2	2			
DS MT No. 4-H40	1	1	2	2	2			
Axial mill/drill unit	—	2	—	2	4			
Radial mill/drill unit	—	2	—	2	4			

Note: V40R and 2SP-V40 turning and multitasking turret toolholders are different.
V100R turning and multitasking turret toolholders are common and thus interchangeable.

* Mill/Drill multitasking turrets

Working Ranges and Maximum Workpiece Shapes

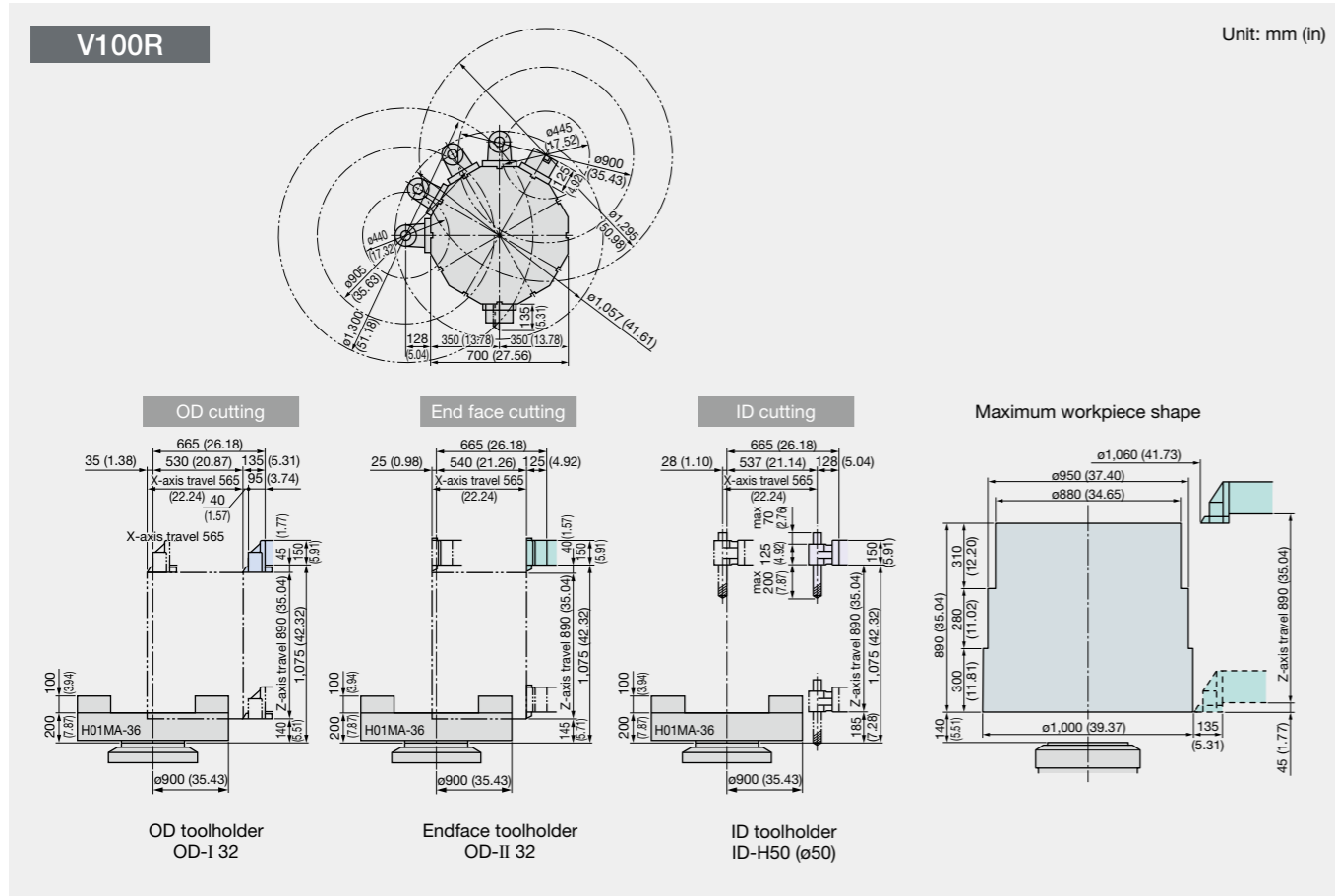
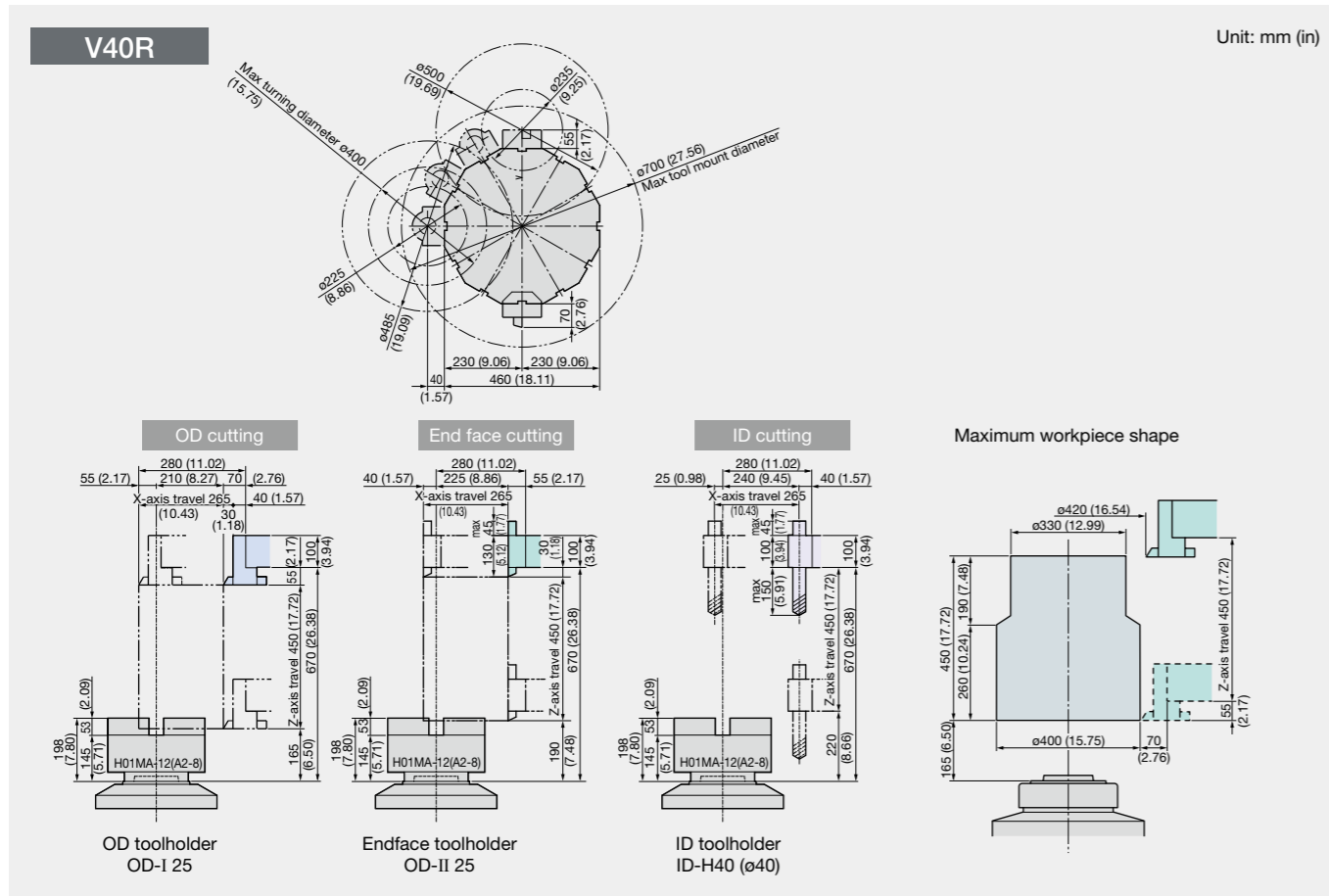

Optional Specifications and Accessories

Low-speed spindle	V100R: 750 min ⁻¹ 55/45 kW (30 min/cont) With transmission	Special coolant pump	0.55 kW 1.5 kW
Multitasking turret	V12M, turning tool 6 locations, milling tool 6 locations, spindle brake V40R/2SP-V40: Milling tool spindle: 2,000 min ⁻¹ (FANUC: 4.0 kW, OSP: 3.5 kW) V100R: Milling tool spindle: 3,000 min ⁻¹ (FANUC: 5.5 kW, OSP: 3.5 kW)	Shower/chip flusher coolant	Increased → 0.88 kW capacity 1.21 kW
Hydraulic power chuck (solid)	V40R/2SP-V40: H01MA-12, H01MA-15, H01MA-18 V100R: H01MA-36, H01MA-40	Coolant gun	0.8 kW (both L/R)
High pressure coolant	(4.0 MPa)	Oil skimmer	Belt system
Chuck miss detection		Coolant level detection	Lowest level
Chuck auto open/close confirm		Chuck air blower	(blast)
Chuck high/low pressure switch		Turret air blower	(blast)
Chuck open/close pedal		Air gun	
Raised machine height	100 mm 150 mm	Mist collector	
Manual chuck	Three-jaw scroll chuck Four-jaw independent chuck Boring mill jaw chuck (V100R only)	Jib crane	100 kg, 200 kg*
Tooling kit	Turning Multitasking	In-process work gauging	
Chip conveyor	Rear Hinge type, scraper type, magnet scraper type Side Hinge type	Touch Setter	Manual axis Auto/manual
Chip bucket		AbsoScale	X axis
Auto front cover open/close		Scale feedback	X axis
		Coolant temperature regulator	For cooling
		Automation specs	Robot Workpiece push-up device (V40) Workpiece seating detection

* 100 kg only for V40R and 2SP-V40

V100R

OSP-P300LA Low-speed spindle

- Spindle speed 750 min⁻¹
- Maximum output 55/45 kW (30 min/cont) (73/60 hp)
- Maximum torque 5,250/4,295 N-m (30 min/cont) (3,860/3,158 ft-lbf)

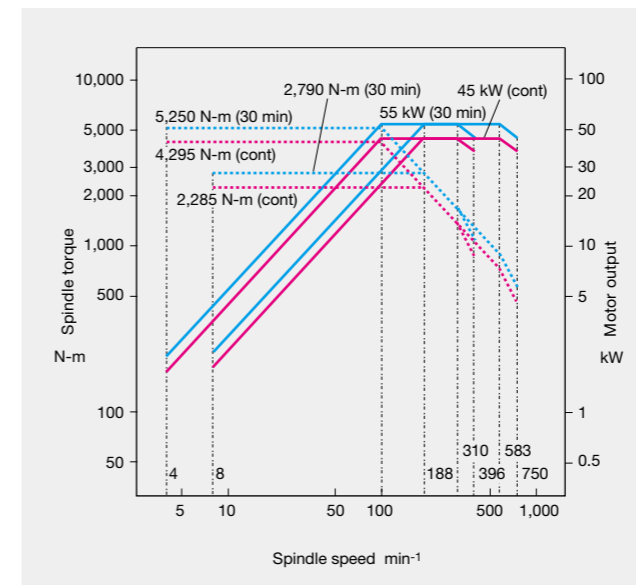

FANUC 31i-B Low-speed spindle

- Spindle speed 750 min⁻¹
- Maximum output 55/45 kW (30 min/cont) (73/60 hp)
- Maximum torque 5,147/4,211 N-m (30 min/cont) (3,785/3,096 ft-lbf)

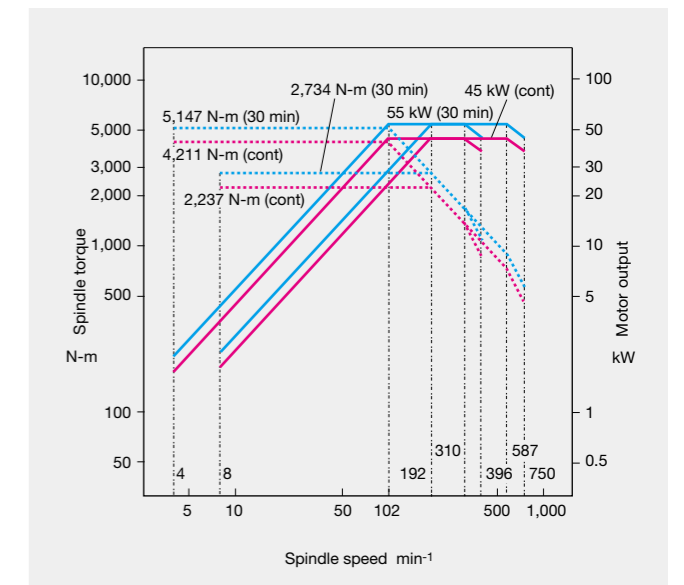

**With revamped operation and responsiveness—
 ease of use for machine shops first!**

Smart factories implement advanced digitization and networking (IoT) in manufacturing to achieve enhanced productivity and added value. The OSP has evolved tremendously as a CNC suited to advanced intelligent technology. Okuma's new control uses the latest CPUs for a tremendous boost in operability, rendering performance, and processing speed. The OSP suite also features a full range of useful apps that could only come from a machine tool manufacturer, making smart manufacturing a reality.

**Smooth, comfortable operation with the feeling
 of using a smart phone**

Improved rendering performance and use of a multi-touch panel achieve intuitive graphical operation. Moving, enlarging, reducing, and rotating 3D models, as well as list views of tool data, programs, and other information can be accomplished through smooth, speedy operations with the same feel as using a smart phone. The screen display layout on the operation screen can also be changed to suit operator preferences and customized for the novice and/or veteran machinists.



“Just what we wanted.”— Refreshed OSP suite apps

This became possible through the addition of Okuma's machining expertise based on requests we heard from real, machine-shop customers. The brain power packed into the CNC, built by a machine tool manufacturer, will “empower shop floor” management.

Routine inspection support
Maintenance Monitor

The Maintenance Monitor displays items for inspections before starting daily operation and regular inspections and the rough estimate of inspection timing. Touching the [INFO] button displays the PDF instruction manual file of relevant maintenance items.

PERIODICAL MAINTENANCE	DAILY INSPECTION	CHANGE MODE
300	Grease for tool clamping unit (HSD)	Supply
301	Packing in tool clamping unit (HSD)	Inspection
320	Brake contour lubrication oil	Replace
411	Hydraulic unit oil	Replace
412	Hydraulic unit line filter	Cleaning
413	Hydraulic unit line filter	Replace
421	Oil for SPCL cooling unit	Replace

[INFO] button

Increased productivity through visualization of motor power reserve
Spindle Output Monitor

Monitoring utilization status even when away from the machine
E-mail Notification

Easy programming without keying in code
Scheduled Program Editor

Get Connected, Get Started, and Get Innovative with Okuma “Monozukuri” *Connect Plan*

Connect, Visualize, Improve

Okuma's Connect Plan is a system that provides analytics for improved utilization by connecting machine tools and visual control of factory operation results and machining records. Simply connect the OSP and a PC and install Connect Plan on the PC to see the machine operation status from the shop floor, from an office, from anywhere. The Connect Plan is an ideal solution for customers trying to raise their machine utilization.

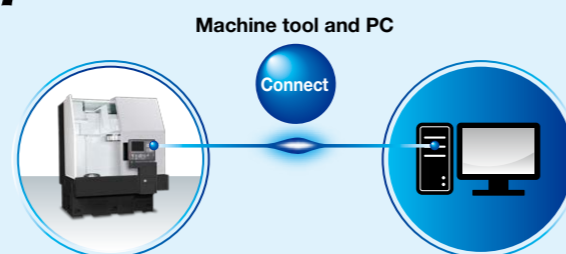

Ensuring smooth machining preparations

Interactive operations Advanced One-Touch IGF-L (Optional)

Part program create

After simple cutting data inputs (interactively), the required machining processes are determined and a part program is created (automatically).

Advanced run

To run the machine directly from the interactive part program screen. When a problem is detected it can be quickly corrected and checked, speeding up first part machining.

Directly change cutting conditions for each process with this process sheet

MACHINING UNIT	TOOL
1	DRILL THR TN 1
2	RGH OD FACE TN 2
3	RGH OD < TN 2
4	RGH ID < TN 3
5	FIN OD < TN 4
6	FIN ID < TN 5

Continuous run Mid-cycle start (finishing repeated) Individual run (machining repeated with this tool only)

Tables make it easy to make mid-cycle or individual process starts

Easy Operation

Operation screen split into four displays

Simultaneous display includes setup work, current position needed in confirming movement in trial machining, NC program, and graphic simulation.



Tool registration

Register data for all of your tools. Since the registered tool data is also used by Okuma auto programming (Advanced One-Touch IGF) and a collision check function (Collision Avoidance System), this screen will complete the entire registering process. When loading a tool in the machine, simply select it from among the registered tools.



Forming soft jaws

Templates like this make it easy to set required jaw shape, tool, and cutting conditions. Part programming not required to do this.



Zero offsets

A simple function key operation is all it takes to shift a zero offset to either the left or right end of a workpiece. The required zero offset will be calculated automatically based on jaw and workpiece lengths.



Standard Specifications

Basic Specs	Control	Turning: X, Z simultaneous 2-axis, Multitasking: X, Z, C simultaneous 3-axis
	Position feedback	OSP full range absolute position feedback (zero point return not required)
	Min / Max command	±99999.999 mm, ±99999.999° 8-digit decimal, Command units: 0.001 mm, 0.01 mm, 1 mm (0.001°, 0.01°, 1°)
	Feed	Override: 0 to 200%
	Spindle control	Direct spindle speed commands override 50 to 200% Constant cutting speed, optimum turning speed designate
	Tool compensation	Tool selection: 32 sets, tool offset: 32 sets
	Display	15-inch color display operational panel, multi touch panel
	Self-diagnostics	Automatic diagnostics and display of program, operation, machine, and NC system problems
	Program capacity	Program storage: 4 GB, operation buffer: 2 MB
	Operations	suite apps
suite operation		Highly reliable touch panel suited to shop floors. One-touch access to suite apps.
Easy Operation		"Single-mode operation" to complete a series of operations, Advanced operation panel/graphics facilitate smooth machine control
Programing		Program management, edit, multitasking, scheduled programs, fixed cycles, special fixed cycles, tool nose R compensation, fixed drilling cycles, arithmetic functions, logic statements, trig functions, variables, branch statements, auto programming (LAP4), programming help
Machine operations		MDI, manual (rapid traverse, pulse handle), load meter, operations help, alarm help, sequence return, manual interrupt & auto return, data I/O, spindle orientation (electric)
Communications/Networks		USB ports, Ethernet
High speed/accuracy		Hi-G control
Energy-saving function	ECO suite	ECO Idling Stop, ECO Power Monitor

Optional Specifications

Item	Kit Specs *1	NML		3D		OT-IGF		OTM	
		E	D	E	D	E	D	E	D
Interactive Programming									
Advanced One-Touch IGF-L *2						●	●		
Advanced One-Touch IGF-L Multitasking *2								●	●
Programming									
Circular threading			●		●		●		●
Program notes			●		●		●		●
User task 2 I/O variables, 8 ea									
Work coordinate system select	10 sets								
	50 sets								
	100 sets								
Tool compensation (Std: 32 sets)	Tool compensation 64 sets								
Common variables 1,000 pcs (Std: 200 pcs)									
Thread matching (spindle orientation required)									
Threading slide hold (G34, G35)									
Variable spindle speed threading (VSST)									
Inverse time feed									
Milling machine specs	Coordinate convert		▲	▲	▲	▲			●
	Profile generate		▲	▲	▲	▲			●
Monitoring									
Real 3D simulation				●	●	●	●	●	●
Cycle time over check			●	●	●	●	●	●	●
Load monitor (spindle, feed axis)				●	●	●	●	●	●
Load monitor no-load detection (load monitor ordered)									
Machine Status Logger									
Tool life management			●		●		●		●
Tool life warning									
Operation end buzzer									
Chucking miss detection	Included in machine specs								
Work counters	Count only								
	Cycle stop								
	Start disabled								
Hour meters	Power ON								
	Spindle rotation								
	NC operating								
NC operation monitor (counter, totaling)			●	●	●	●	●	●	●
NC work counter (stops at full count with alarm)									
Status indicator (triple lamp) Type C [Type A, Type B]			●	●	●	●	●	●	●
Measuring									
In-process work gauging	Included in machine specs								
Z-axis automatic zero offset by touch sensor									
C-axis automatic zero offset by touch sensor									
Gauge data output	File output								
Post-process work gauging interface	Set levels (5-level, 7-level)								
	BCD								
	RS-232C (dedicated channel)								
Touch Setter [M, A]	Included in machine specs								

Item	Kit Specs *1	NML		3D		OT-IGF		OTM	
		E	D	E	D	E	D	E	D
External Input/Output and Communication Functions									
RS-232C connector									
DNC link	DNC-T3								
	DNC-C/Ethernet								
	DNC-DT								
USB (additional)	2 additional ports possible								
Automation/Untended Operation									
Auto power shutoff M02, alarm									
Warmup function (by calendar timer)									
Tool retract cycle									
External program selections	A (pushbutton) 8 types								
	B (rotary switch) 8 types								
	C (digital switch) BCD, 2-digit								
	C2 (external input) BCD, 4-digit								
Other company robots, loaders, interfaces	Type B (machine)								
	Type C (robot and loader)								
	Type D								
	Type E								
Cycle time reduction *3	Operation time reduction		●	●	●	●	●	●	●
High-Speed/High-Accuracy Functions									
Pitch error compensation									
AbsoScale detection *3									
Hi-Cut Pro			▲	▲	▲	▲			●
Other Functions									
Collision Avoidance System (CAS)									
One-Touch Spreadsheet									
Machining Navi L-g									
Harmonic spindle speed control (HSSC)			●	●	●	●	●	●	●
Spindle dead-slow cutting									
Spindle speed setting									
Manual cutting feed									
Spindle power peak cutting									
Short circuit breaker									
External M signals [2 sets, 4 sets, 8 sets, ()]									
Edit interlock									
OSP-VPS (Virus Protection System)									

*1. NML: Normal, 3D: Real 3D simulation, OT-IGF: One-Touch IGF, OTM: One-Touch M
E: Economy, D: Deluxe
*2. Real 3D Simulation included
*3. Engineering discussions required.
*4. Collision Avoidance System not available on 2SP-V40.
Note: ▲ Triangle items for M function (milling tool) machines only.

Standard Specifications

No. of controlled axes	X, Z axes simultaneously (2SP: X, Z axes simultaneously × 2)
Interpolation system	Positioning, straight line, taper, arc, threading
Command system	Parallel absolute incremental command
Min/max inputs	Both X, Z axes 0.001, ±99999.999 mm, decimal point input
Operating panel	10.4 in color TFT, display language: English / Japanese
Spindle control	Spindle control 4-digit direct command, constant peripheral speed control, spindle orientation (1 point M19), spindle override 50 to 150%
Feed	Feed rate override 0 to 200%, pulse handle
Program input	Program memory capacity 64 KB (160 m) 2SP-V R/L total is 64KB (160 m), no. of registered programs: 63 (2SP-V R/L total is 125), expansion program editing, programmable data input, program protection key switch
Compensation	Nose-radius comp, no of tool compensations: 32 (2SP-V R/L total is 32), tool dimensions/wear compensation, tool offset, counter input, direct input of measured tool compensation
Monitoring	Operating time, no. of parts display, electronic buzzer
Machine operations	AI contour control I

Optional Specifications

No. of controlled axes	More simultaneously controlled axes (X-Z-C axes)*
Interpolation system	Fine coordinate interpolation* Cylindrical interpolation* Cs contouring*
Monitoring	Graphic display Tool counter Work counter Multi-counter Hour meters Status indicator Tool life management Abnormal load detection (spindle + feed axes) Electronic buzzer
Machine operations	Continuous threading Spindle orientation (1 point, 4 point) Portable pulse handle Automatic power shutoff Circuit breaker
Other functions	Illumination in control panel Air conditioning within control panel

* Required with multitasking specs

Program input	Program memory capacity	128 KB (320 m)
		256 KB (640 m)
		512 KB (1,280 m)
		1 MB (2,560 m)
		2 MB (5,120 m)
		4 MB (10,240 m)
		8 MB (20,480 m)
	More registered programs	125 sets
		250 sets
		500 sets
Compensation	External program selection	
	RS-232C interface	
	Custom macro	
	Custom macros, additional common variables	
	Coordinate selection 6 sets	
	M spindle rigid tapping	
	Fixed drilling cycle	
	Chamfering, corner	
	Combination fixed cycles I, II	
	Simultaneous editing of multiple programs	
	Program restart	
	Spare M codes (4, 8)	
	2nd shape tool offset	
	Pitch error compensation (X-axis, X/Z axes)	
	No. of tool compensations 64 sets (with 2SP-V40, R/L total is 64, 128)	

■ Dimensional and Installation Drawings

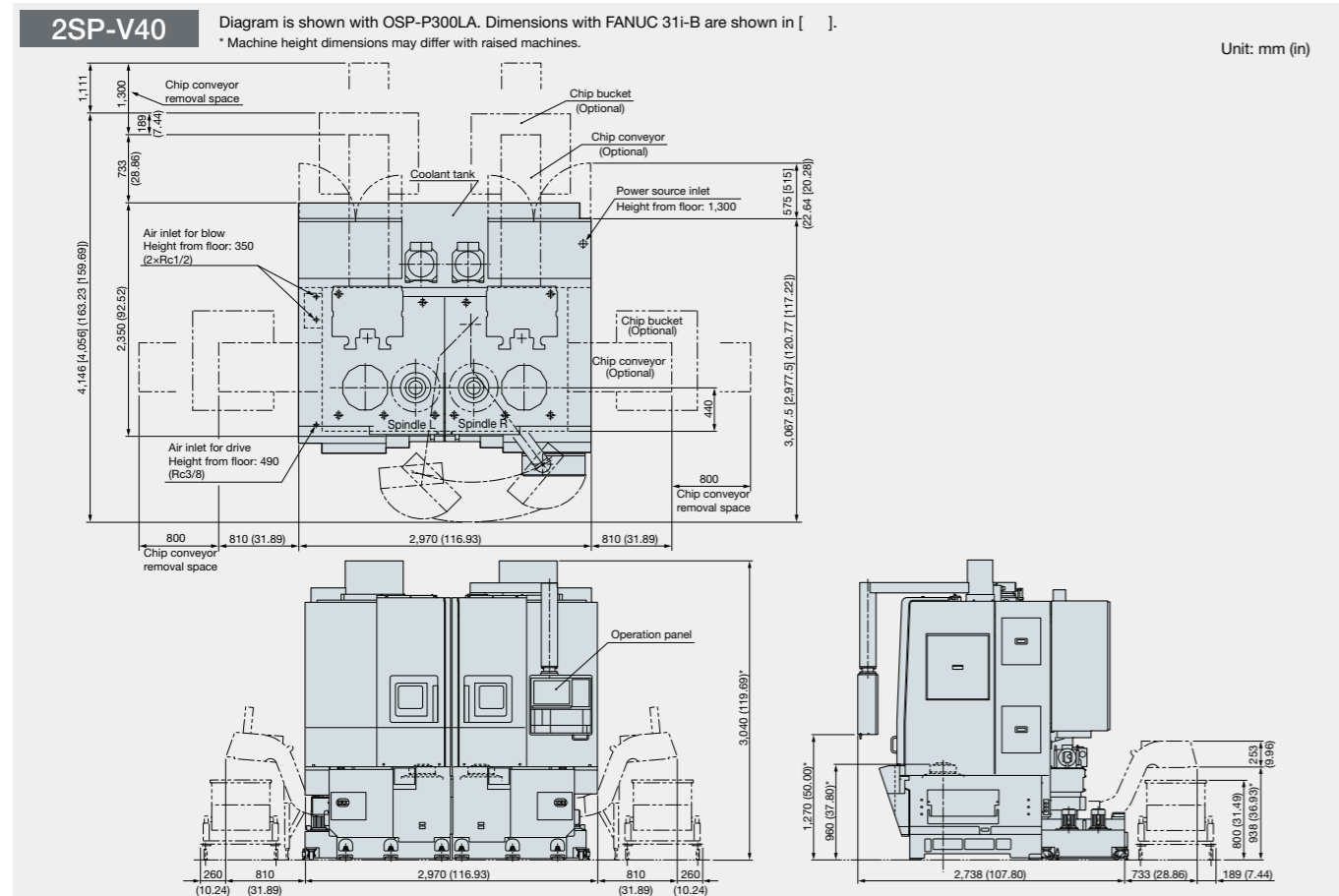
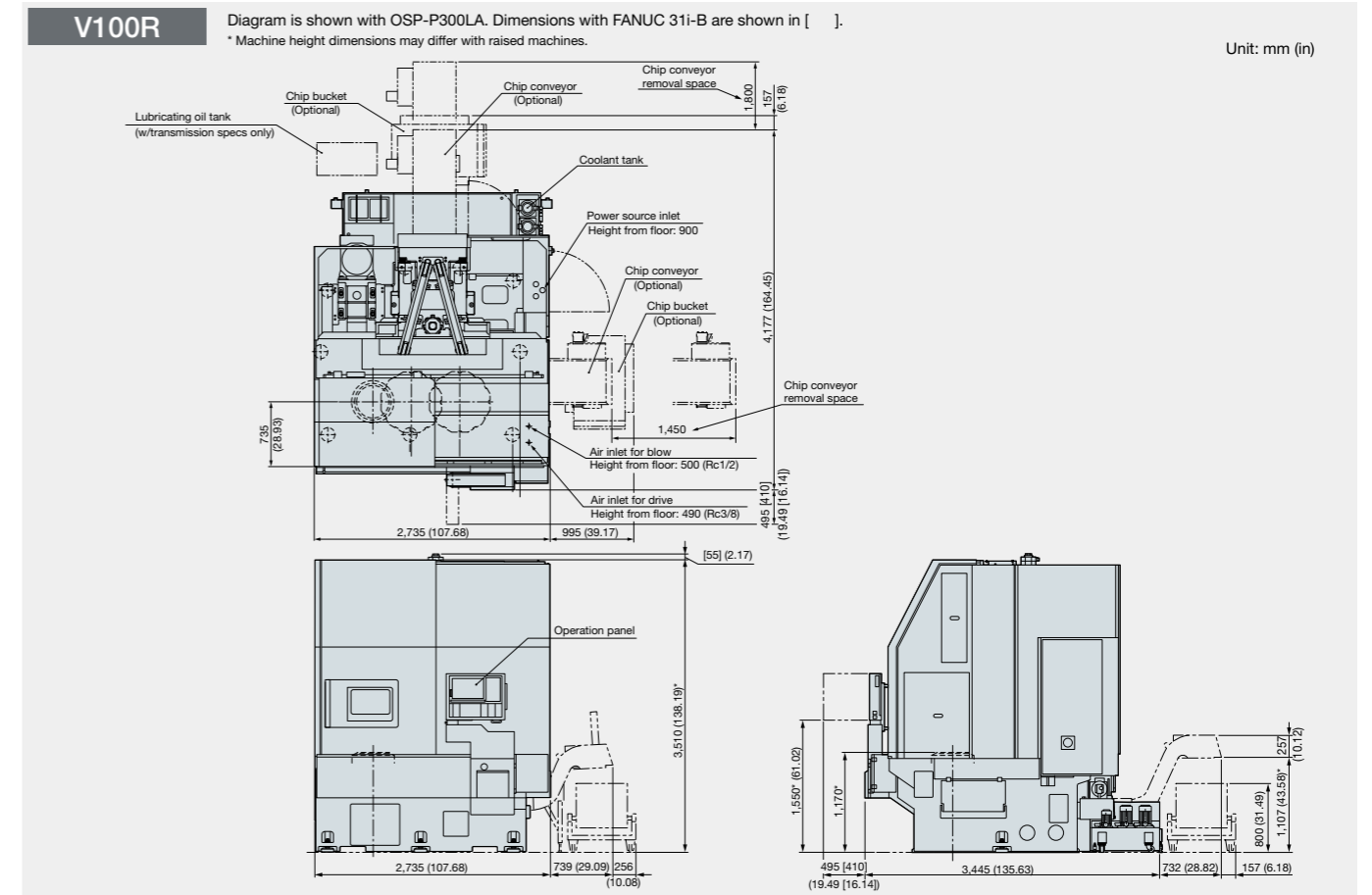
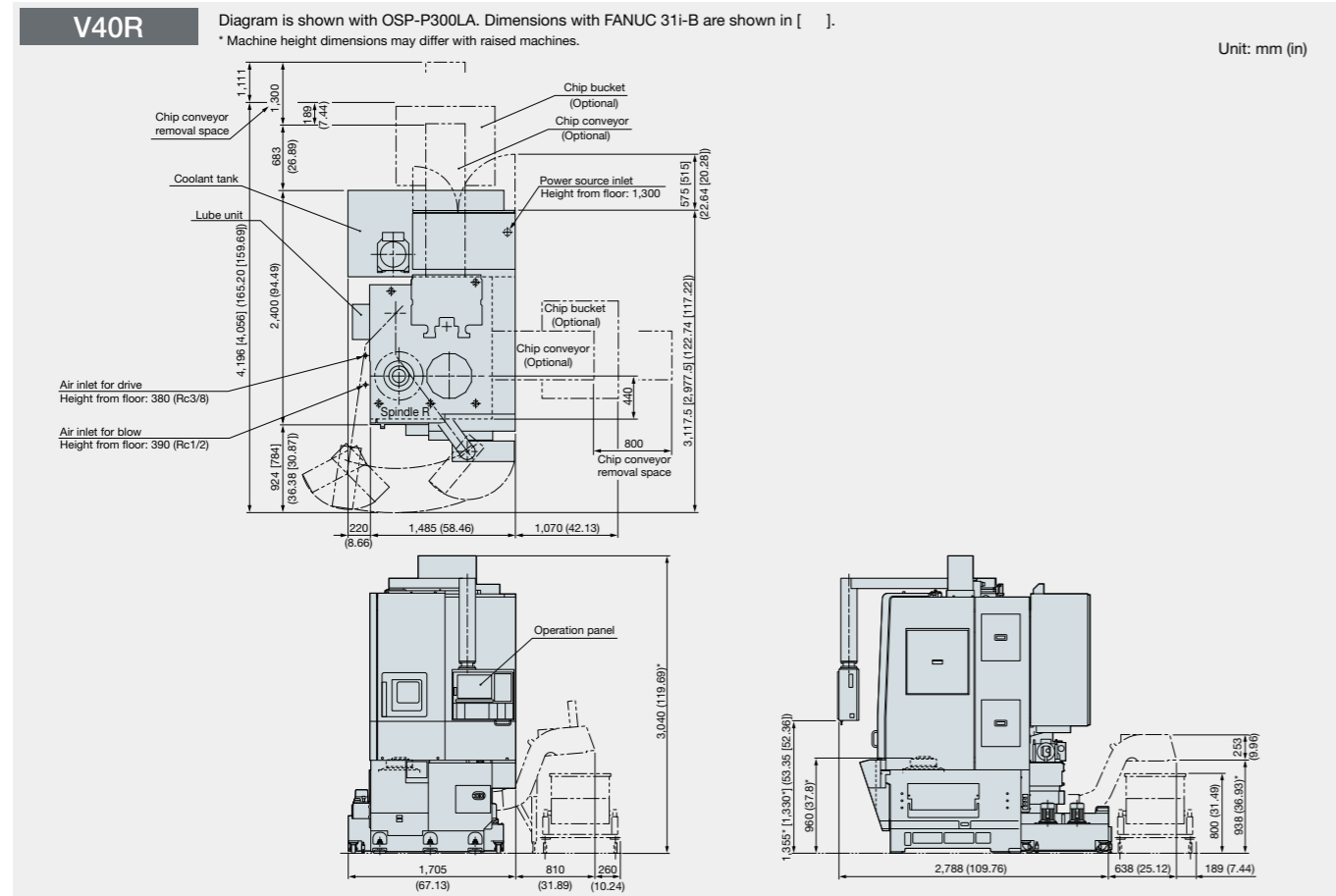

When using Okuma products, always read the safety precautions mentioned in the instruction manual and attached to the product.

The specifications, illustrations, and descriptions in this brochure vary in different markets and are subject to change without notice.
Pub No. V series-E-(9a)-200 (Dec 2019)



OKUMA Corporation

Oguchi-cho, Niwa-gun
Aichi 480-0193, Japan
TEL: +81-587-95-7825 FAX: +81-587-95-6074

This product is subject to the Japanese government Foreign Exchange and Foreign Trade Control Act with regard to security controlled items; whereby Okuma Corporation should be notified prior to its shipment to another country.